



2N[®] Helios IP Verso

Modular IP Intercom



Installation Manual

Version 2.3

www.2n.cz

The 2N TELEKOMUNIKACE a.s. is a Czech manufacturer and supplier of telecommunications equipment.



The product family developed by 2N TELEKOMUNIKACE a.s. includes GSM gateways, private branch exchanges (PBX), and door and lift communicators. 2N TELEKOMUNIKACE a.s. has been ranked among the Czech top companies for years and represented a symbol of stability and prosperity on the telecommunications market for almost two decades. At present, we export our products into over 120 countries worldwide and have exclusive distributors on all continents.



2N[®] is a registered trademark of 2N TELEKOMUNIKACE a.s. Any product and/or other names mentioned herein are registered trademarks and/or trademarks or brands protected by law.



2N TELEKOMUNIKACE a.s. administers the FAQ database to help you quickly find information and to answer your questions about 2N products and services. On www.faq.2n.cz you can find information regarding products adjustment and instructions for optimum use and procedures „What to do if...“.



2N TELEKOMUNIKACE a.s. hereby declares that the 2N[®] Helios IP Verso product complies with all basic requirements and other relevant provisions of the 1999/5/EC directive. For the full wording of the Declaration of Conformity see the CD-ROM (if enclosed) or our website at www.2n.cz.



This device complies with part 15 of the FCC Rules. Operation is subject to the following two conditions: (1) This device may not cause harmful interference, and (2) this device must accept any interference received, including interference that may cause undesired operation.



The 2N TELEKOMUNIKACE a.s. is the holder of the ISO 9001:2009 certificate. All development, production and distribution processes of the company are managed by this standard and guarantee a high quality, technical level and professional aspect of all our products.

Content

1. Product Overview	4
1.1 Components and Associated Products	6
1.2 Terms and Symbols	21
2. Description and Installation	22
2.1 Before You Start	23
2.2 Mechanical Installation	24
2.3 Electric Installation	90
2.4 Extending Module Connection	95
2.5 Completion	105
3. Function and Use	108
3.1 Configuration	109
3.2 Intercom Control as Viewed by External User	111
3.3 Electronic Buttons equipped Intercom as Viewed by External User	114
3.4 Intercom Control as Viewed by Internal User	115
3.5 Maintenance	117
4. Technical Parameters	118
5. Supplementary Information	121
5.1 Troubleshooting	122
5.2 Directives, Laws and Regulations	123
5.3 General Instructions and Cautions	125

1. Product Overview

Here is what you can find in this section:

- [1.1 Components and Associated Products](#)
- [1.2 Terms and Symbols](#)

Basic Features

2N® Helios IP Verso is an elegant and reliable intercom equipped with lots of useful functions. Thanks to SIP support and compatibility with major brands of PBX manufacturers, it can benefit from using VoIP networks. **2N® Helios IP Verso** can be used as a door or special purpose intercom for office buildings, residential areas and other applications.

2N® Helios IP Verso is a modular system: the user determines its configuration according to the needs of the particular installation. Unlike other intercoms, **2N® Helios IP Verso** is not delivered as a compact unit. After choosing the installation mode and particular modules, the user gets separate parts to be assembled using the plug&play connections. This approach allows for unique individual combinations and also leaves space for adding of additional modules later on.

Wide angle HD camera – allows the tenant to see the calling person on his or her videophone or PC screen in high resolution. The camera itself is hidden behind a darkened glass, so it is not visible. The intercom is equipped with night vision, which automatically selects the night/day mode according to light.

Quick dial buttons – there are 146 quick dial buttons in total in multiple button modules. For each button, up to three separate phone numbers plus substitute users can be defined, which ensures that the called user is reached whenever needed. The buttons are backlit with a clear mechanical response. The nametag surface is scratch resistant.

Keypad – is a keypad module that allows the user to use the intercom as a code lock and dial a phone number or phonebook position of the called user.

RFID card reader – the card reader module brings the access control functionality according to the RFID card or keyfob. With the advanced features, other functions can

be RFID card controlled too.

Electric lock control – As part of the access system, the electrical lock can be controlled by a code entered on the keypad or the called phone, with the RFID card, via a PC application, etc. When necessary, more electrical outputs can be added. Numerous parameters allow for a wide spectrum of applications.

Robustness – **2N® Helios IP Verso** is designed as a vandal resistant intercom, which withstands mechanical or weather conditions with no need to purchase extra accessories.

Audio quality – using the automatic echo cancelling system, full duplex communication is available at any time.

The installation of 2N® Helios IP Verso is very easy, all you have to do is assemble the required parts and modules and attach the network cable. The modules are plug&play, so there is no need to configure them manually. The intercom can be supplied from a 12 V DC power source, or using a PoE switch.



Use your PC with any internet browser to **configure 2N® Helios IP Verso** . Apply the **2N® Helios IP Manager** to configure extensive installations of multiple intercoms.

Advantages of Use

- Elegant design
- Weather resistant
- Various modes of installation (flush, surface, plasterboard)
- Sensitive microphone and loud speaker
- Both-way audio communication – acoustic echo cancellation
- Integrated colour HD camera with wide-angle lense and hidden night vision
- Selectable number of quick dial buttons with nametags and backlight
- Optional numeric keypad with backlight
- Option to have multiple modules of the same kind – for example, card reader for both entering and leaving the building
- Integrated switches of electric locks with wide setting options
- Optional integrated RFID card reader module
- PoE or 12 V DC power supply
- Configuration using web interface or dedicated PC application
- VoIP standard SIP 2.0 support
- 999 Phone Book positions
- 20 user time profiles
- Video codecs (H.263, H.263+, H.264, MPEG-4, MJPEG)
- Audio codecs (G.711, G.729, G.722, L16/16kHz)
- HTTP server for configuration
- SNTP client for time synchronisation
- RTSP server for audio and video streaming, ONVIF compatible
- SMTP client for email sending, Picture to Email feature
- TFTP/HTTP client for automated firmware and configuration upgrade and update

1.1 Components and Associated Products



Basic Units



	
Part No. 9155101 Basic unit	Part No. 9155101C Basic unit with camera

Caution

- There must be just one (with/without a camera) basic unit in every installation. The basic unit installation requires two frame/box positions; the other position, however, is left for additional module installation.

Frames

		
Part No. 9155011 Flush mounting frame, 1 module	Part No. 9155012 Flush mounting frame, 2 modules	Part No. 9155013 Flush mounting frame, 3 modules

		
Part No. 9155021 Surface mounting frame, 1 module	Part No. 9155022 Surface mounting box, 2 modules	Part No. 9155023 Surface mounting box, 3 modules

✔ **Tip**





- The 1-module frame is used when another module is added to the existing installation or when the module is mounted to an extended interconnecting cable for an outgoing reader, for example.

✔ **Tip**

- Be sure to order the covering frame for the flush or plasterboard mounting box together with the flush mounting box
 - 1-module frame (Part No. **9155011**) – 1-module flush mounting box (Part No. **9155014**)
 - 2-module frame (Part No. **9155012**) – 2-module flush mounting box (Part No. **9155015**)
 - 3-module frame (Part No. **9155013**) – 3-module flush mounting box (Part No. **9155016**)

Extending Modules



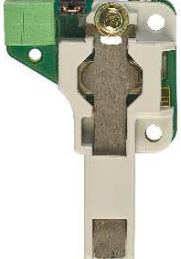









<p>Part No. 9155030</p> <p>2N® Helios IP Verso – Infopanel</p> <p>The Infopanel module helps you place such information into the intercom installation as house number, opening hours and similar data. The Infopanel backlight is software controlled.</p>	<p>Part No. 9155031</p> <p>2N® Helios IP Verso – Keypad</p> <p>The numeric keypad module helps you dial users via their phonebook positions or phone numbers, control the lock and use other code-accessible functions. The keypad digits and symbols are backlit.</p>	<p>Part No. 9155032</p> <p>2N® Helios IP Verso – RFID Card Reader, 125 kHz</p> <p>The card reader module provides you with access control via contactless cards or keyfobs. The module supports the 125 kHz EM-41xx or HID Proximity cards.</p>
		
<p>Part No. 9155033</p> <p>2N® Helios IP Verso – RFID Card Reader, 13.56 MHz</p> <p>The card reader module provides you with access control via contactless cards or keyfobs. The module supports the following 13.56 MHz cards or other carriers:</p> <p>ISO14443A Mifare Classic 1k & 4k, DESFire EV1, Mini, Plus S&X, SmartMX, Ultralight, Ultralight C, SLE44R35, my-d move (SLE66Rxx), PayPass, Legic Advant</p> <p>ISO14443B Calypso, CEPAS, Moneo, SRI512, SRT512, SRI4K, SRIX4K, PicoPass, HID iCLASS</p>	<p>Part No. 9155034</p> <p>2N® Helios IP Verso – I/O module</p> <p>The module provides logical inputs and outputs for sensor integration or door control. The module is installed under another module, i.e. needs no separate position.</p>	<p>Part No. 9155035</p> <p>2N® Helios IP Verso – buttons</p> <p>A module with 5 mechanical quick dial buttons. The buttons are backlit and can include nametags.</p>
		

<p>Part No. 9155036</p> <p>2N® Helios IP Verso – electronic buttons Not available yet - A module with 5 electronic buttons for quick dialling from the phonebook. Use the arrow buttons to browse through every 5 phonebook positions and press the button next to the name in the current set of five positions to dial.</p>	<p>Part No. 9155037</p> <p>2N® Helios IP Verso – Wiegand module The module helps you interconnect your system with other systems via the Wiegand interface. The module is installed under another module, i.e. needs no separate position.</p>	<p>Part No. 9155038</p> <p>2N® Helios IP Verso – Tamper Switch The module secures your system against tampering by detecting intercom opening or top frame removing. The module is installed on a special place and needs no separate position.</p>
		
<p>Part No. 9155039 Blind module</p>	<p>Part No. 9155040 2N® Helios IP Verso – RFID Card Reader, 13 MHz, NFC ready</p> <p>The card reader module provides you with access control via contactless cards or keyfobs. The module supports the following 13.56 MHz cards or other carriers:</p> <p>ISO14443A Mifare Classic 1k & 4k, DESFire EV1, Mini, Plus S&X, SmartMX, Ultralight, Ultralight C, SLE44R35, my-d move (SLE66Rxx), PayPass, Legic Advant</p> <p>ISO14443B Calypso, CEPAS, Moneo, SRI512, SRT512, SRI4K, SRIX4K, PicoPass, HID iCLASS</p> <p>NFC SmartPhone with NFC/HCE support, since Android version 4.3</p>	<p>Part No. 9155050 1 m Extension cable</p>
		

Part. No. 9155051 Blind button		
--	--	--

Mounting Accessories

		
<p>Part No. 9155014 Flush mounting box, 1 module</p>	<p>Part No. 9155015 Flush mounting box, 2 modules</p>	<p>Part No. 9155016 Flush mounting box, 3 modules</p>
		
<p>Part No 9155061 Backplate 1 module</p>	<p>Part No 9155062 Backplate 2 modules</p>	<p>Part No 9155063 Backplate 3 modules</p>
		
<p>Part No 9155064 Backplate 2(w)x2(h) modules</p>	<p>Part No 9155065 Backplate 2(w)x3(h) modules</p>	<p>Part No 9155066 Backplate 3(w)x2(h) modules</p>

		
Part No 9155067 Backplate 3(w)x3(h) modules		

Part No.	Name	Description
9155101	2N® Helios IP Verso – Basic unit	There must be just one (with/without a camera) basic unit in every installation. The basic unit installation requires two frame/box positions; the other position, however, is left for additional module installation.
9155101C	2N® Helios IP Verso – Basic unit with camera	
9155011	2N® Helios IP Verso – Flush mounting frame, 1 module	A 1-module covering frame for the flush/plasterboard mounting box. The 1-module frame is used when another module is added to the existing installation or when 1 module is mounted to an extended interconnecting cable for an outgoing reader, for example. Be sure to order the flush mounting frame together with the 1-module flush mounting box No. 9155014.
9155012	2N® Helios IP Verso – Flush mounting frame, 2 modules	A 2-module covering frame for the flush/plasterboard mounting box. Be sure to order the flush mounting frame together with the 2-module flush mounting box No. 9155015.
9155013	2N® Helios IP Verso – Flush mounting frame, 3 modules	A 3-module covering frame for the flush/plasterboard mounting box. Be sure to order the flush mounting frame together with the 3-module flush mounting box No. 9155016.
9155014	2N® Helios IP Verso – Flush mounting box, 1 module	The box is designed for flush or plasterboard mounting of 1-module sets and delivered including accessories for multiple box assemblies.

9155015	2N® Helios IP Verso – Flush mounting box, 2 modules	The box is designed for flush or plasterboard mounting of 2-module sets and delivered including accessories for multiple box assemblies.
9155016	2N® Helios IP Verso – Flush mounting box, 3 modules	The box is designed for flush or plasterboard mounting of 3-module sets and delivered including accessories for multiple box assemblies.
9155021	2N® Helios IP Verso – Surface mounting frame, 1 module	A 1-module covering frame for the surface mounting box. The 1-module frame is used when another module is added to the existing installation or when 1 module is mounted to an extended interconnecting cable for an outgoing reader, for example.
9155022	2N® Helios IP Verso – Surface mounting frame, 2 modules	A 2-module covering frame for the surface mounting box.
9155023	2N® Helios IP Verso – Surface mounting frame, 3 modules	A 3-module covering frame for the surface mounting box.
9155061	2N® Helios IP Verso – Backplate 1 module	A 1-module backplate for glass or not flat surface installation.
9155062	2N® Helios IP Verso – Backplate 2 modules	A 2-module backplate for glass or not flat surface installation.
9155063	2N® Helios IP Verso – Backplate 3 modules	A 3-module backplate for glass or not flat surface installation.





9155064	2N® Helios IP Verso – Backplate 2(w)x2(h) modules	A 2(w)x2(h)-module backplate for glass or not flat surface installation.
9155065	2N® Helios IP Verso – Backplate 2(w)x3(h) modules	A 2(w)x3(h)-module backplate for glass or not flat surface installation.
9155066	2N® Helios IP Verso – Backplate 3(w)x2(h) modules	A 3(w)x2(h)-module backplate for glass or not flat surface installation.
9155067	2N® Helios IP Verso – Backplate 3(w)x3(h) modules	A 3(w)x3(h)-module backplate for glass or not flat surface installation.
9155030	2N® Helios IP Verso – Infopanel	The Infopanel module helps you place such information into the intercom installation as house number, opening hours and similar data. The Infopanel backlight is software controlled.
9155031	2N® Helios IP Verso – Keypad	The numeric keypad module helps you dial users via their phonebook positions or phone numbers, control the lock and use other code-accessible functions. The keypad digits and symbols are backlit.
9155032	2N® Helios IP Verso – RFID Card Reader, 125 kHz	The card reader module provides you with access control via contactless cards or keyfobs. The module supports the 125 kHz EM-41xx or HID Proximity cards.
9155033	2N® Helios IP Verso – RFID Card Reader, 13 MHz	The card reader module provides you with access control via contactless cards or keyfobs. The module supports the following 13.56 MHz cards or other carriers: ISO14443A Mifare Classic 1k & 4k, DESFire EV1, Mini, Plus S&X, SmartMX, Ultralight, Ultralight C, SLE44R35, my-d move (SLE66Rxx), PayPass, Legic Advant ISO14443B Calypso, CEPAS, Moneo, SRI512, SRT512, SRI4K, SRIX4K, PicoPass, HID iCLASS
9155034	2N® Helios IP Verso – I/O module	The module provides logical inputs and outputs for sensor integration or door control. The module is installed under another module, i.e. needs no separate position.

9155035	2N® Helios IP Verso – buttons	A module with 5 mechanical quick dial buttons. The buttons are backlit and can include nametags.
9155036	2N® Helios IP Verso – electronic buttons	Not available yet - A module with 5 electronic buttons for quick dialling from the phonebook. Use the arrow buttons to browse through every 5 phonebook positions and press the button next to the name in the current set of five positions to dial.
9155037	2N® Helios IP Verso – Wiegand module	The module secures your system against tampering by detecting intercom opening or top frame removing. The module is installed on a special place and needs no separate position.
9155038	2N® Helios IP Verso – Tamper Switch	The module secures your system against tampering by detecting intercom opening or top frame removing. The module is installed on a special place and needs no separate position.
9155040	2N® Helios IP Verso – RFID Card Reader, 13 MHz, NFC ready	The card reader module provides you with access control via contactless cards or keyfobs. The module supports the following 13.56 MHz cards or other carriers: ISO14443A Mifare Classic 1k & 4k, DESFire EV1, Mini, Plus S&X, SmartMX, Ultralight, Ultralight C, SLE44R35, my-d move (SLE66Rxx), PayPass, Legic Advant ISO14443B Calypso, CEPAS, Moneo, SRI512, SRT512, SRI4K, SRIX4K, PicoPass, HID iCLASS NFC SmartPhone with NFC/HCE support, since Android version 4.3

2N® Helios IP Verso is designed for outdoor applications and requires no additional roof.

Choose the proper frame and, if necessary, mounting box type depending on your particular **2N® Helios IP Verso** installation needs.



Internal Units

		
<p>Part No. 91378365</p> <p>2N® Indoor Touch - black</p> <p>The elegant internal touch panel, 2N® Indoor Touch, is suitable for all 2N® Helios IP intercoms. On the panel's display not only can you find out who is at the door, but also start a conversation with the visitor, open the lock or turn on the light in the entrance hall.</p>	<p>Part No. 91378365WH</p> <p>2N® Indoor Touch - white</p> <p>The elegant internal touch panel, 2N® Indoor Touch, is suitable for all 2N® Helios IP intercoms. On the panel's display not only can you find out who is at the door, but also start a conversation with the visitor, open the lock or turn on the light in the entrance hall.</p>	
		
<p>Part No. 91378366</p> <p>2N® Indoor Touch - black</p> <p>WiFi</p> <p>The elegant internal touch panel, 2N® Indoor Touch, is suitable for all 2N® Helios IP intercoms. On the panel's display not only can you find out who is at the door, but also start a conversation with the visitor, open the lock or turn on the light in the entrance hall.</p>	<p>Part No. 91378367</p> <p>2N® Indoor Touch - black</p> <p>WiFi + NFC</p> <p>The elegant internal touch panel, 2N® Indoor Touch, is suitable for all 2N® Helios IP intercoms. On the panel's display not only can you find out who is at the door, but also start a conversation with the visitor, open the lock or turn on the light in the entrance hall.</p>	<p>Part No. 91378368</p> <p>2N® Indoor Touch - black</p> <p>NFC</p> <p>The elegant internal touch panel, 2N® Indoor Touch, is suitable for all 2N® Helios IP intercoms. On the panel's display not only can you find out who is at the door, but also start a conversation with the visitor, open the lock or turn on the light in the entrance hall.</p>

VoIP Phones

	
<p>Part No. 91378357 Grandstream GXV3240 VoIP videophone</p> <p>GXV3240 is the successor to the popular GXV3140 model, which allows comfortable video calls in the IP network. Touchscreen and keyboard control.</p>	<p>Part No. 91378358 Grandstream GXV3275 VoIP videophone</p> <p>GXV3275 is the successor to the popular GXV3175 model, which allows comfortable video calls in the IP network. Touchscreen control.</p>

Electric Locks

		
<p>Part No. 932070E BEFO 1211</p> <p>12V / 600 mA</p>	<p>Part No. 932080E BEFO 1221 with momentary pin</p> <p>12V / 600 mA</p> <p>For opening of the lock a short electrical impuls is sufficient, which unlocks the lock. Lock is then open until someone closes the door.</p>	<p>Part No. 932090E BEFO 1211MB with mechanical blocking</p> <p>12V / 600 mA</p> <p>Enables mechanically close or open the lock. When opened, the lock is open all the time. When closed, it behaves as standart electrical lock.</p>



 **Tip**







- FAQ: [Electric locks - Difference between locks in 2N® Helios IP accesories](#)





Power Supply

		
<p>Part. No. 91378100 PoE injector - without cable</p> <p>Part. No. 91378100E PoE injector - with EU cable</p> <p>Part. No. 91378100US PoE injector - with US cable</p> <p>For power supply of intercom via ethernet cable when PoE switch is not available.</p>	<p>Part No. 91341481E Stabilised 12 V / 2 A power supply needs to be used when no PoE is available.</p>	<p>Part No. 932928 12 V transformer</p> <p>For external power supply of the lock with 12V AC voltage.</p>

Additional Modules

		
<p>Part No. 9159010 Security relay</p> <p>A handy add-on that significantly enhances door entry security as it prevents tampering with the intercom and forced opening of the lock. To be installed between intercom and lock, powered by the intercom.</p>	<p>Part No. 9137420E USB RFID card reader 125kHz External RFID card reader for connection to a PC using a USB interface. Suitable for system management and the addition of EM41xx cards via the PC application, 2N® Helios IP Manager.</p>	<p>Part No. 9137410E External IP Relay - 1 output</p> <p>Standalone IP device which can be controlled by HTTP commands sent by Helios IP intercom, which can thus control devices on unlimited distance.</p>

		
<p>Part No. 9137411E External IP Relay - 4 outputs, PoE</p> <p>Standalone IP device which can be controlled by HTTP commands sent by Helios IP intercom, which can thus control devices on unlimited distance.</p>	<p>Part No. 9134165E RFID card, 125 kHz</p>	<p>Part No. 9134166E RFID key fob, 125 kHz</p>
		
<p>Part No. 9134173 Mifare RFID card, 13.56 MHz</p>	<p>Part No. 9134174 Mifare RFID card, 13.56 MHz</p>	<p>Part No. 9159014EU/US/UK</p> <p>2N® 2Wire</p> <p>(set of 2 adaptors and power source for EU/US/UK)</p> <p>The 2N® 2Wire converter allows you to use existing wiring (2 wires) from your original door bell or door intercom to connect any IP device. You don't have to configure anything, and you only need one 2N® 2Wire unit at each end of the cable and a power source connected to at least one of these units. The 2N® 2Wire unit then provides PoE power not only to the second converter, but also to all other connected IP end devices.</p>

		
<p>Part No. 9159050</p> <p>Induction Loop</p>	<p>Part No. 9159013</p> <p>Exit button</p> <p>A button for connection to a logic input for opening a door inside a building.</p>	<p>Part No. 9159012</p> <p>Magnetic door contact</p> <p>Set for installation on a door, enabling the status of door opening to be ascertained. Used when the intercom is used for door protection, to detect when the door is not closed or forced open.</p>
		
<p>Part No. 9159030</p> <p>External 125kHz RFID card reader</p> <p>Secondary reader for connection to an internal reader. Allows control of card entry from both sides of the door. IP67 cover, also suitable for exteriors. Reads EM4100 and EM4102 cards.</p>	<p>Part No. 9154004</p> <p>Water-proof metal button</p>	

✔ **Tip**

- For more accessories and particular advice please contact your local distributor of 2N products.

✔ **Tip**

- FAQ: [Induction loop - How to connect it with 2N® Helios IP](#)

1.2 Terms and Symbols

The following symbols and pictograms are used in the manual:

 **Safety**

- **Always abide** by this information to prevent persons from injury.

 **Warning**

- **Always abide** by this information to prevent damage to the device.

 **Caution**

- **Important information** for system functionality.

 **Tip**

- **Useful information** for quick and efficient functionality.

 **Note**

- Routines or advice for efficient use of the device.

2. Description and Installation

Here is what you can find in this section:

- [2.1 Before You Start](#)
- [2.2 Mechanical Installation](#)
- [2.3 Electric Installation](#)
- [2.4 Extending Module Connection](#)
- [2.5 Completion](#)

2.1 Before You Start

Product Completeness Check

Before you start please check whether the contents of the package of your new **2N[®] Helios IP Verso** complies with the following list.

- 1× **2N[®] Helios IP Verso**

2.2 Mechanical Installation

Mounting Types Overview

Refer to the table below for a list of mounting types and necessary components. You can assemble multiple units in all mounting types.

Flush mounting – classic bricks

- incl. hollow bricks, thermally insulated walls, etc.

What you need for mounting:

- a properly cut hole as instructed in the box package
- Plaster, mounting glue, mounting foam or mortar as necessary
- **2N® Helios IP Verso** , flush mounting boxes and frames
- 1× module: box Part No. **9155014**, frame Part No. **9155011**
- 2× modules: box Part No. **9155015**, frame Part No. **9155012**
- 3× modules: box Part No. **9155016**, frame Part No. **9155013**

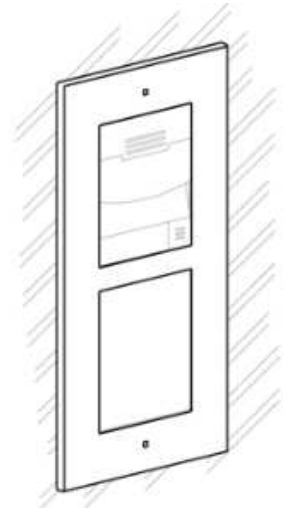

Flush mounting – plasterboard

What you need for mounting:

- a properly cut hole as instructed in the box package
- **2N® Helios IP Verso** , flush mounting boxes and frames
- 1× module: box Part No. **9155014**, frame Part No. **9155011**
- 2× modules: box Part No. **9155015**, frame Part No. **9155012**
- 3× modules: box Part No. **9155016**, frame Part No. **9155013**

Surface mounting

- concrete and steel structures, entry barrier columns, interior, etc.

What you need for mounting:

- **2N® Helios IP Verso** plus the respective frames
- 1× module: frame Part No. **9155021**
- 2× modules: frame Part No. **9155022**
- 3× modules: frame Part No. **9155023**

For not flat surface use according to the module number backplate Part No **9155061 - 9155067**



Caution

- The warranty does not apply to the product defects and failures arisen as a result of improper mounting (in contradiction herewith). The manufacturer is neither liable for damage caused by theft within an area that is accessible after the attached electric lock is switched. The product is not designed as a burglar protection device except when used in combination with a standard lock, which has the security function.
- When the proper mounting instructions are not met, water might get in and destroy the electronics. It is because the communicator circuits are under continuous voltage and water infiltration causes an electro-chemical reaction. The manufacturer's warranty shall be void for products damaged in this way!

General Mounting Principles

Tip

- Select flush mounting where possible to make your product elegant looking, more vandal resistant and more secure.
- You are advised to buy the flush mounting boxes in advance and commission your building company to do the masonry for you. This approach helps you put your intercom exactly in the vertical position.

⚠ Caution

- Make sure that the diameter of the dowel holes is accurate to avoid falling out of the dowels! Use the mounting glue to secure the dowels if necessary.
- Make sure that the depth of the dowel holes is accurate!
- Do not use low-quality dowels to avoid their pulling out of the wall!
- Having removed the front panel, make sure that no dirt gets inside the product (especially onto the sealing surface).
- Never turn **2N® Helios IP Verso** to align the box assembly after mounting. Make sure that the flush mounting boxes have been installed accurately.
- Check the plasterboard wall and room interior pressure values. If the difference between the values is too great (as a result, e.g., of overpressure ventilation), separate the intercom using, for example, the mounting box enclosed and seal the cable passage to avoid speaker damage.
- Surface mounting may cause problems on places exposed to potential vandalism (such as public garages, etc.). In this case, use steel anchoring elements instead of the dowels and screws included in the delivery.
- The place for surface mounting must be flat with maximum inequality of 0.5 mm. (e.g. desk materials, glass, cutted stone etc). If the place is not flat, use flush mounting, backplate **Part No 9155061 - 9155067** or equal the wall surface.

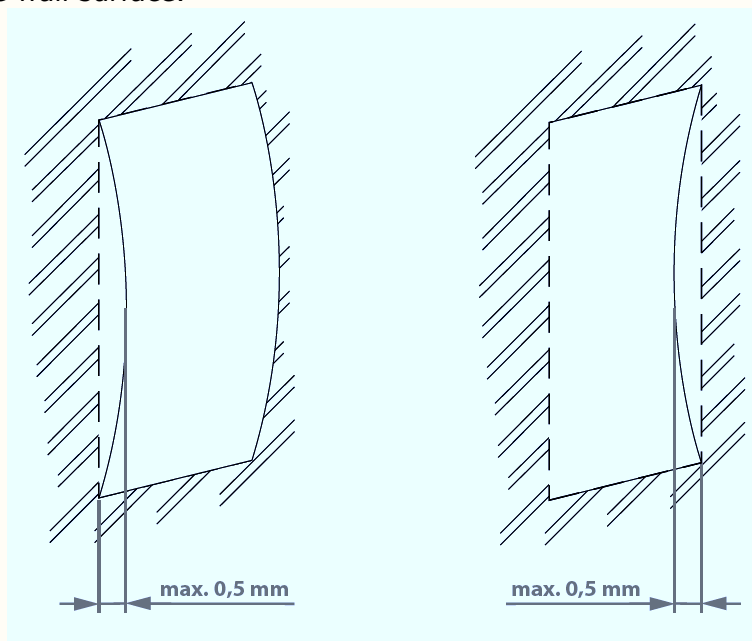

⚠ Safety

- Eliminate the risk of personal injury! Surface mounting is not recommended for narrow passages or places where people's attention is distracted by something else. The manufacturer shall not be liable for injuries in such cases!

Module Installation

- [2.2.1 One Module Box](#)
- [2.2.2 Two Modules Box](#)
- [2.2.3 More Two Modules Boxes](#)
- [2.2.4 Three Modules Box](#)
- [2.2.5 More Three Modules Boxes](#)
- [2.2.6 Tamper and I/O Module](#)

2.2.1 One Module Box

Flush mounting box mounting – classics bricks

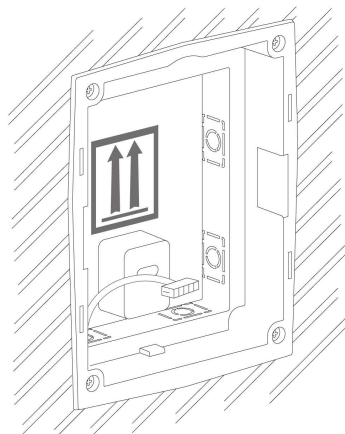
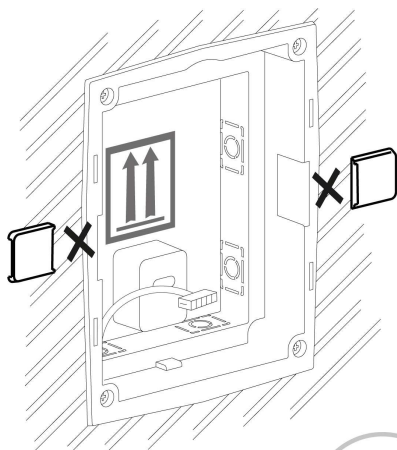
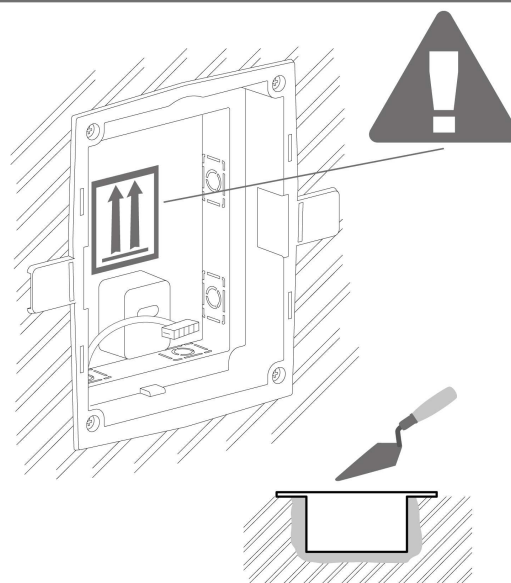
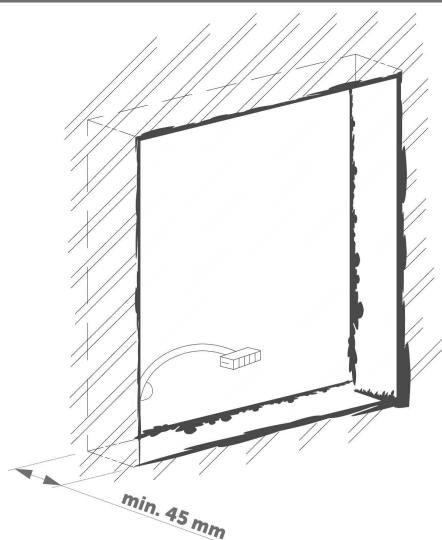

Flush mounting box mounting – plasterboard

1x

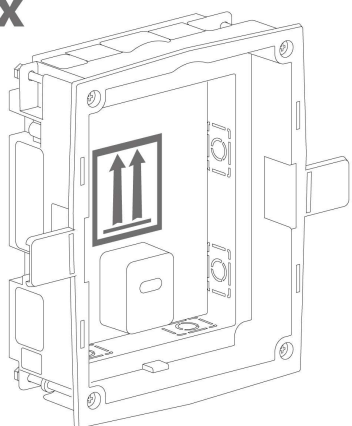

min 108(W) x 136(H)

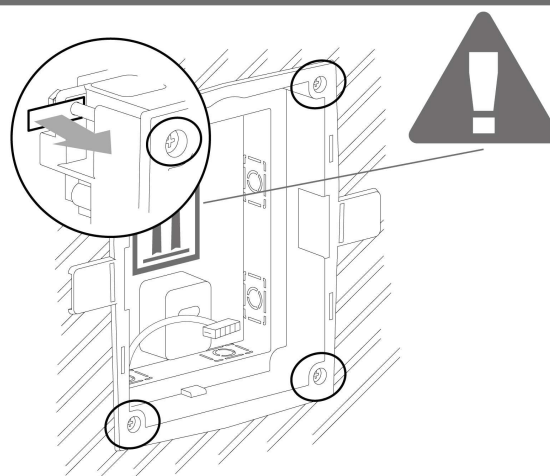
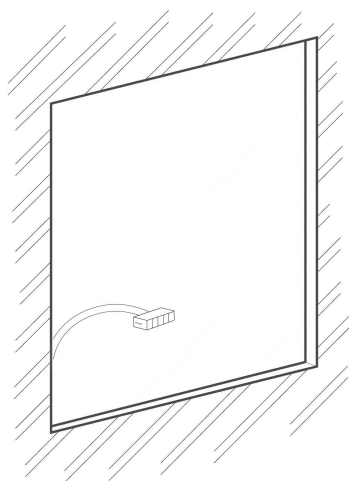
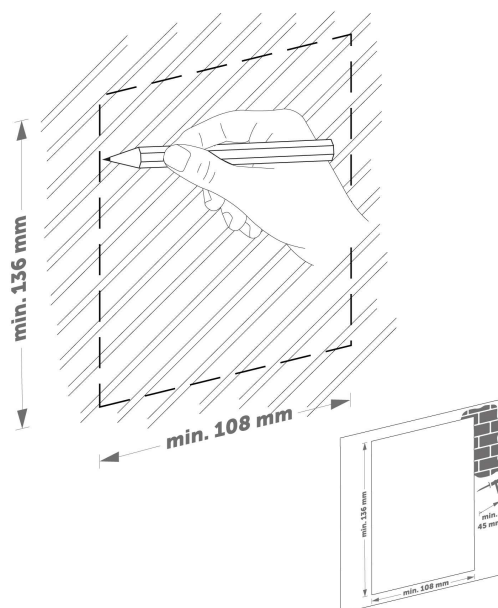

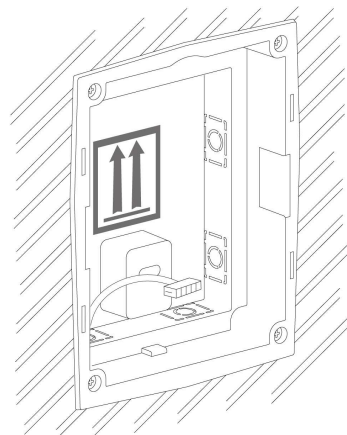
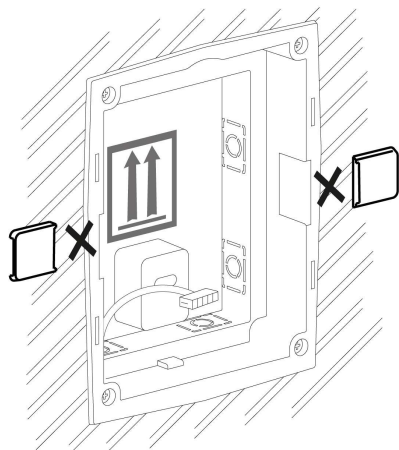

Flush module mounting

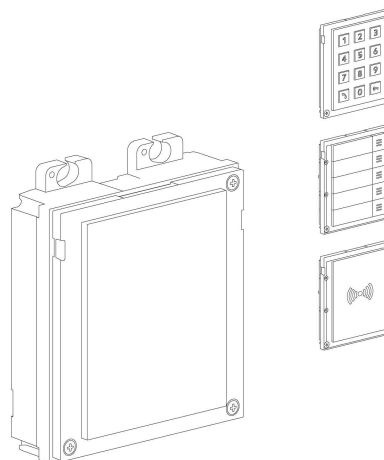
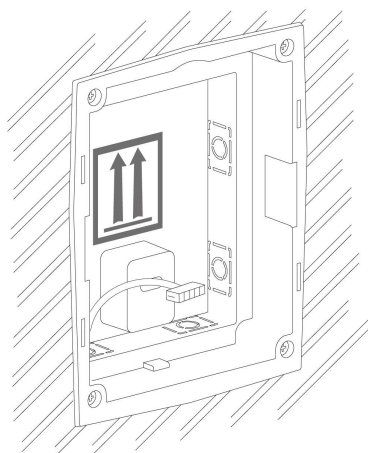

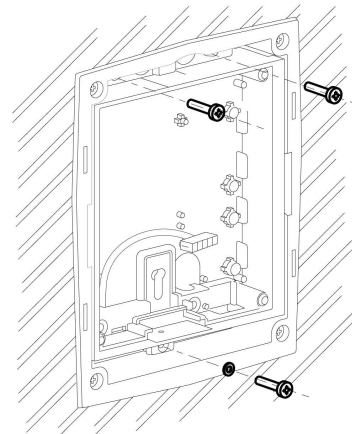
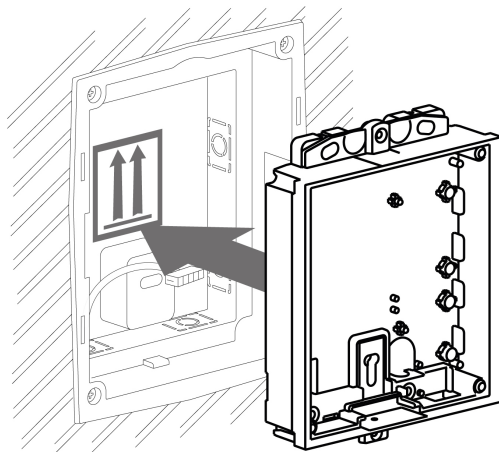
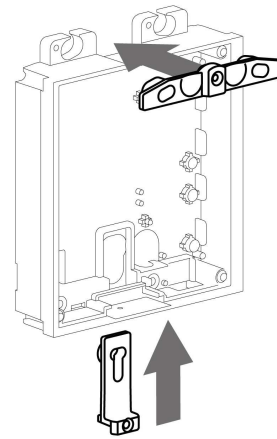
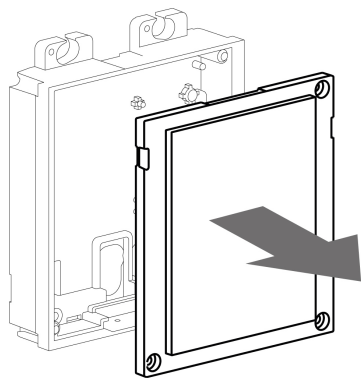

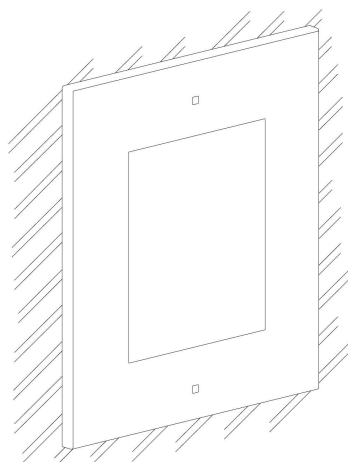
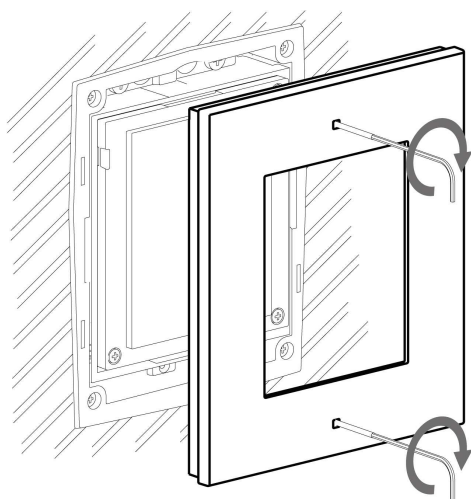
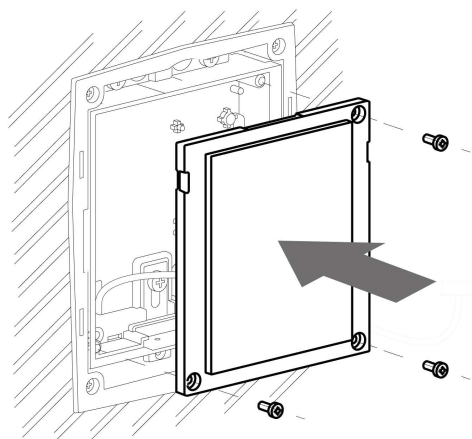
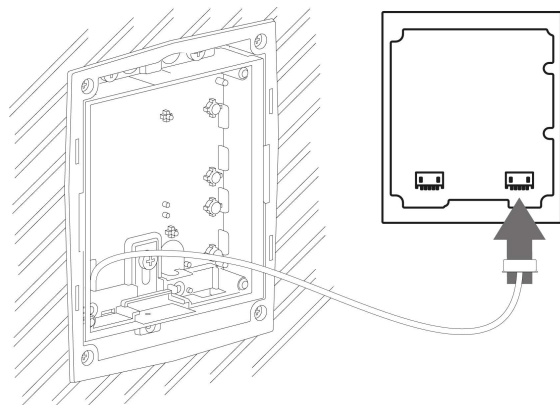

Surface module mounting

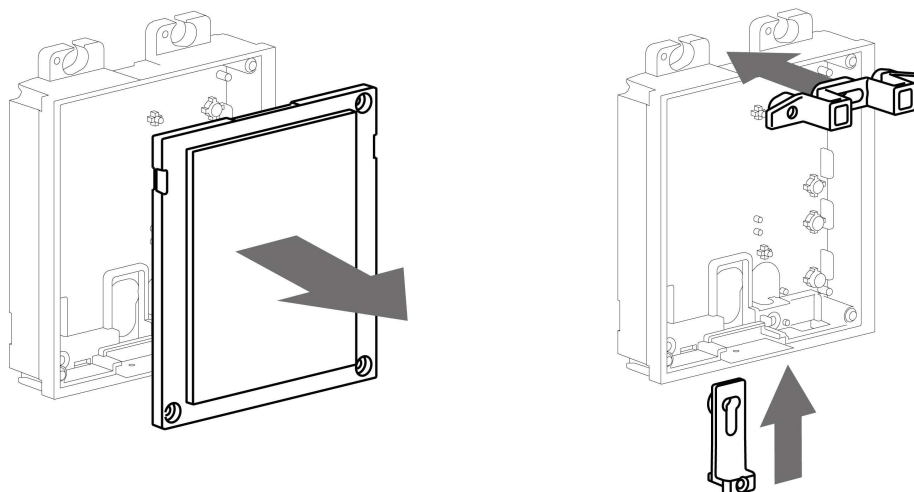
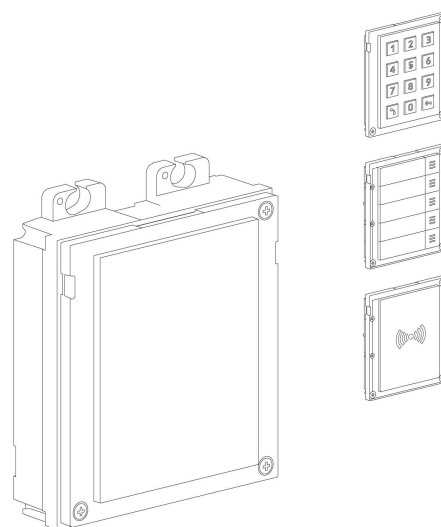
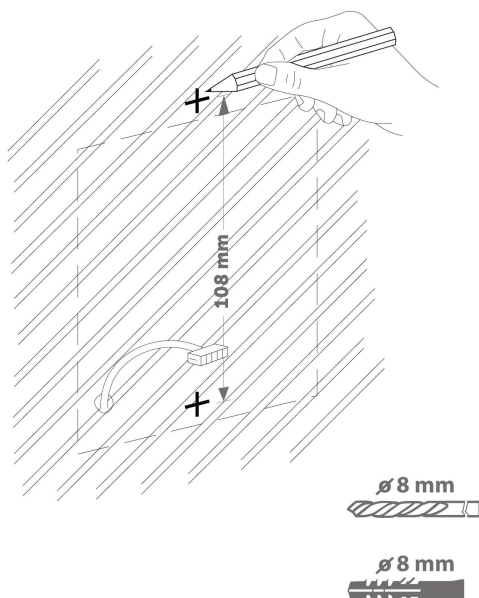

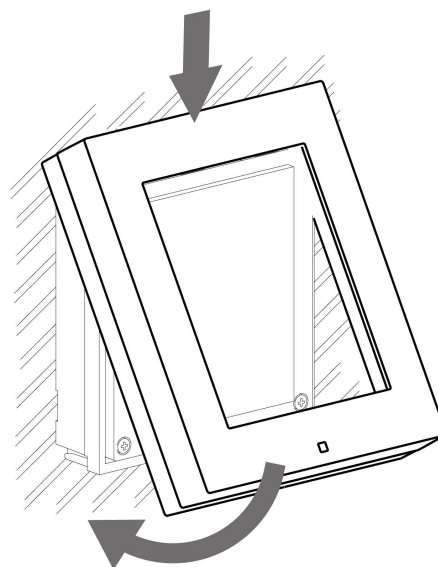
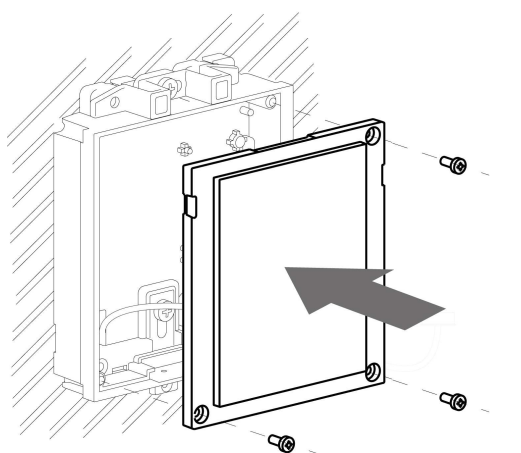
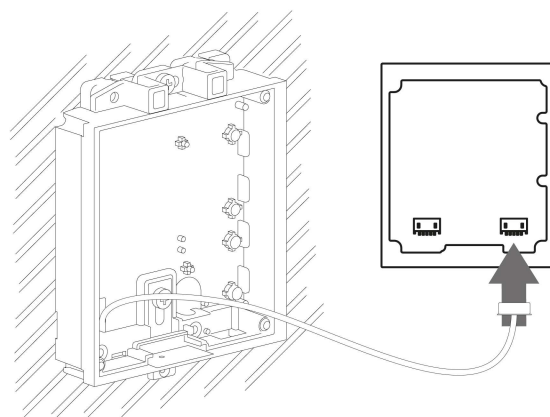
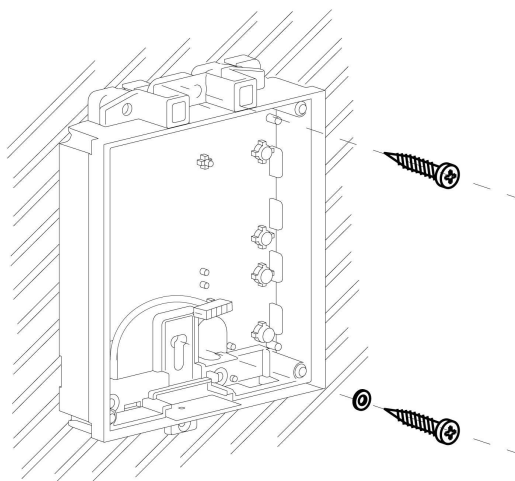

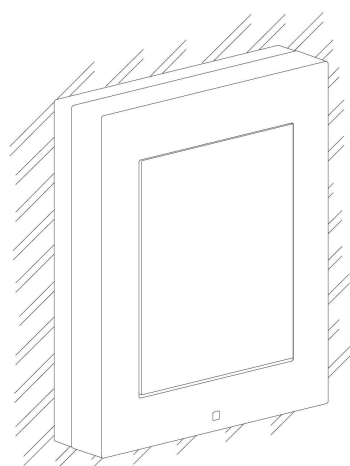
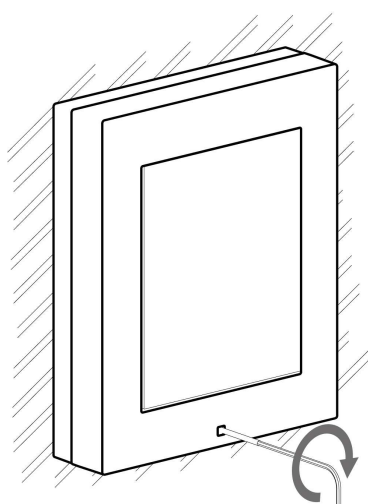

2.2.2 Two Modules Box

Flush mounting box mounting – classics bricks

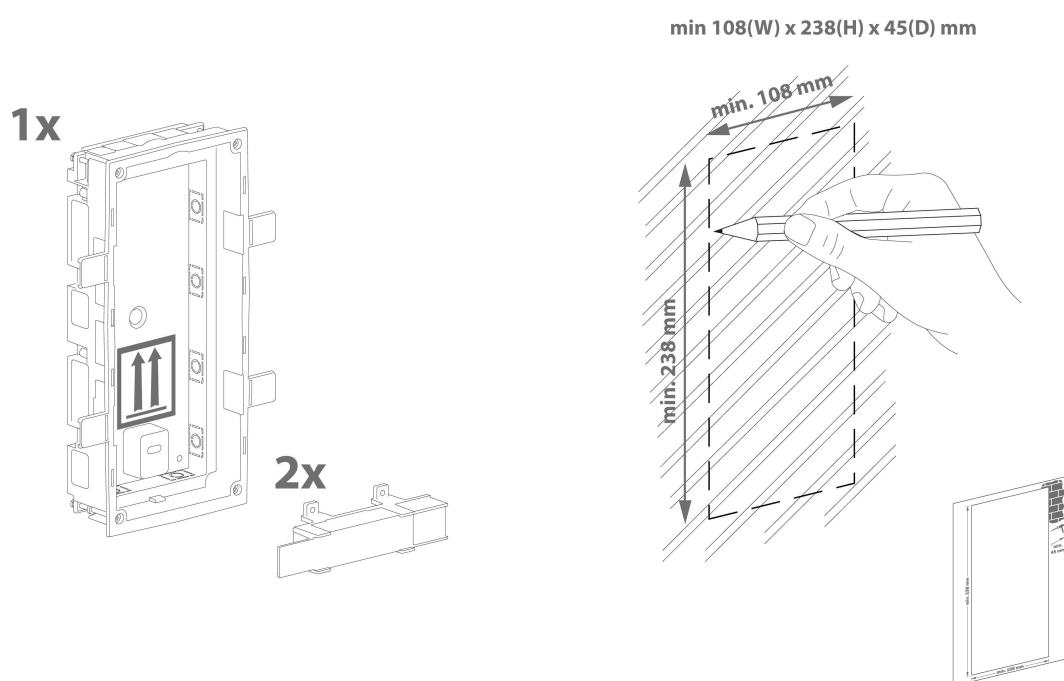

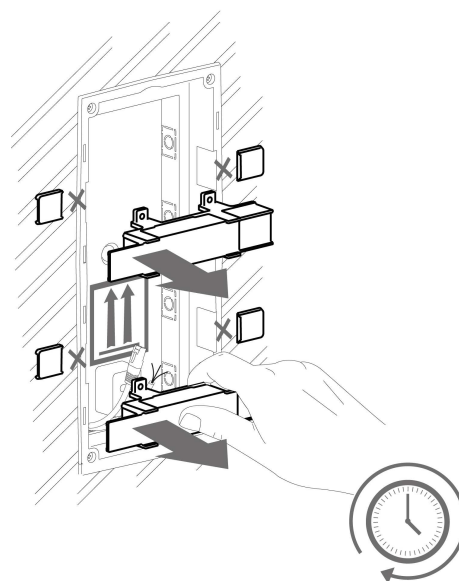
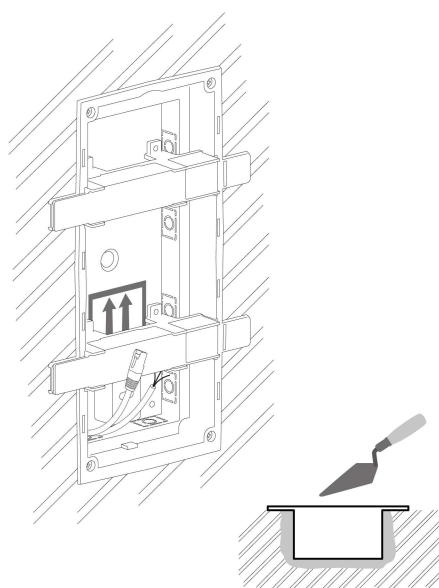
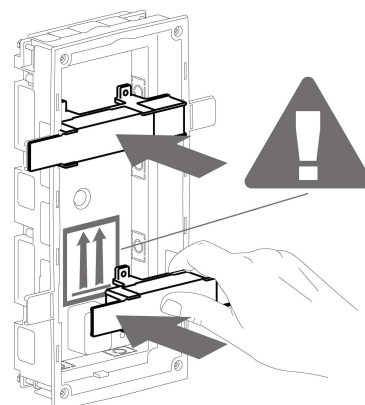
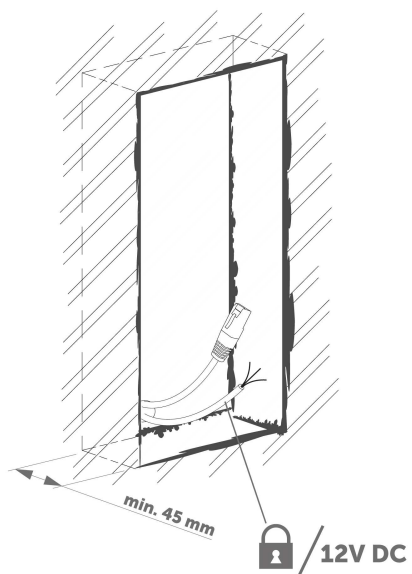

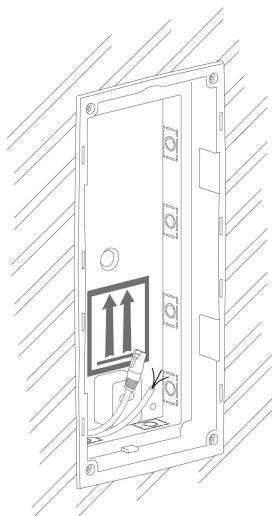

Flush mounting box mounting – plasterboard

1x

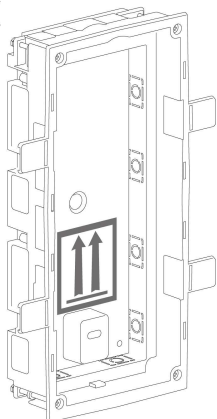

min 108(W) x 238(H) mm

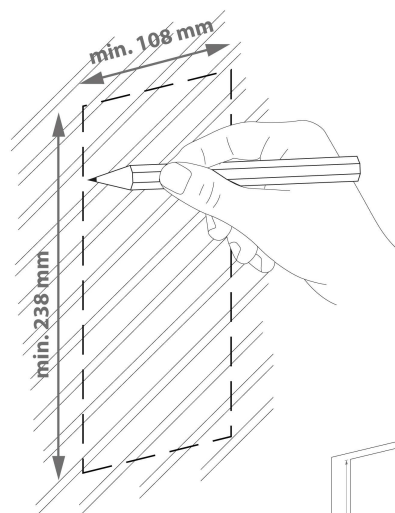

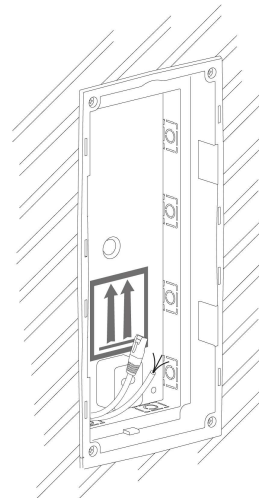
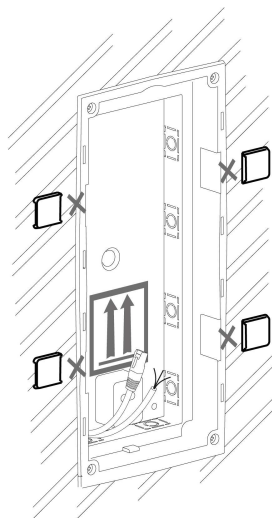
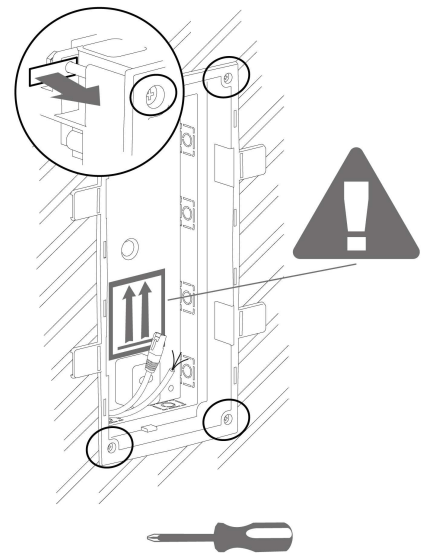
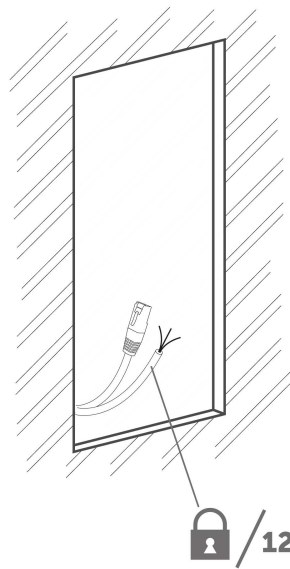

Flush module mounting

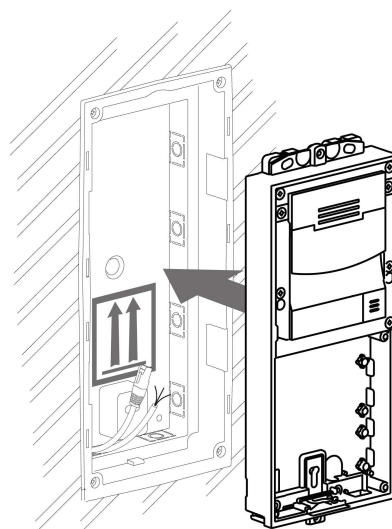
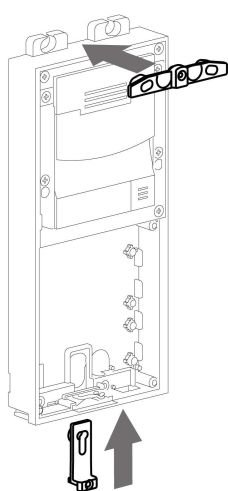
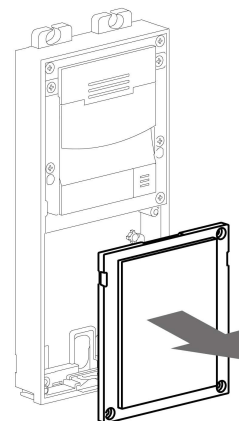
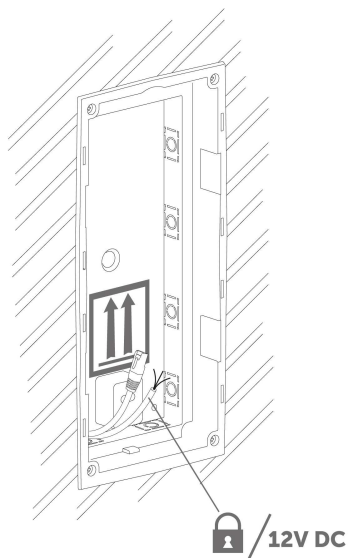

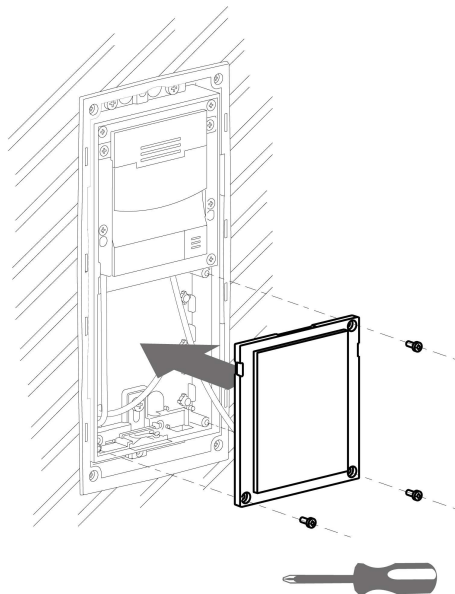
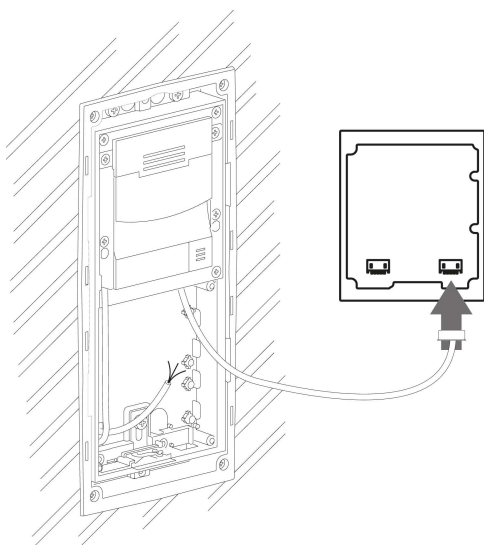
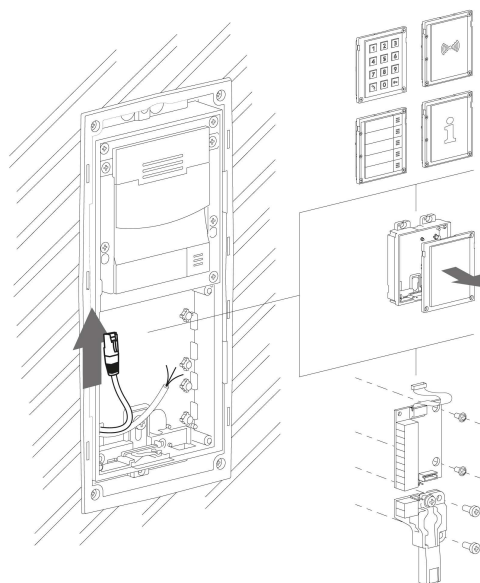
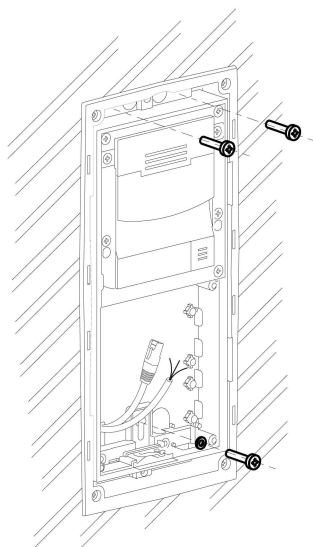

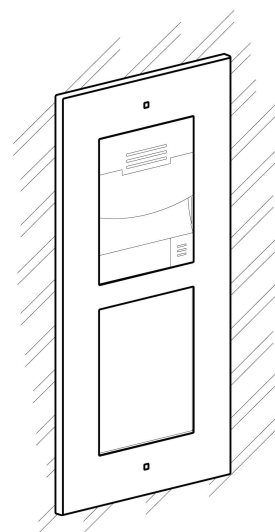
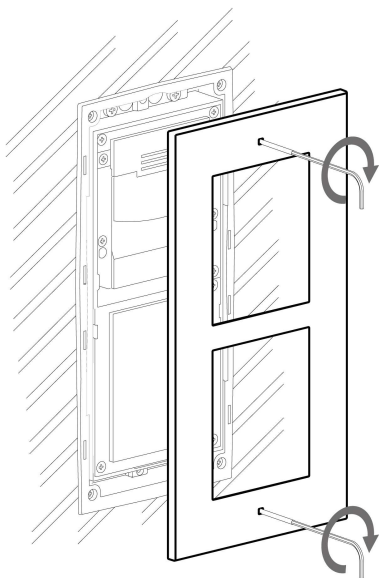

Surface module mounting

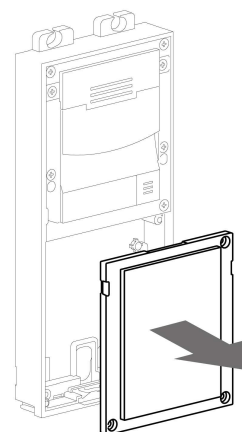
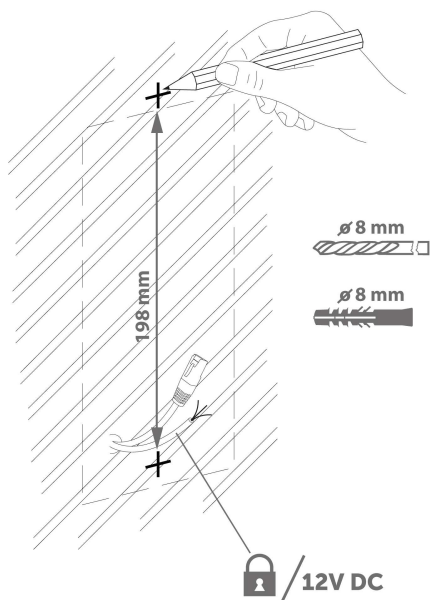

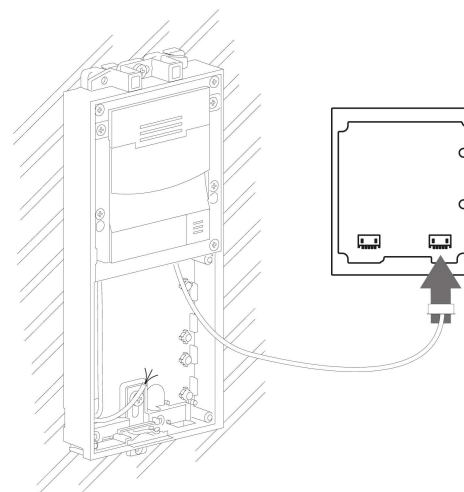
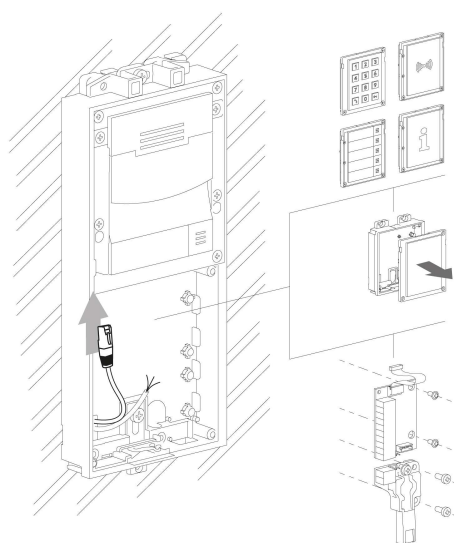
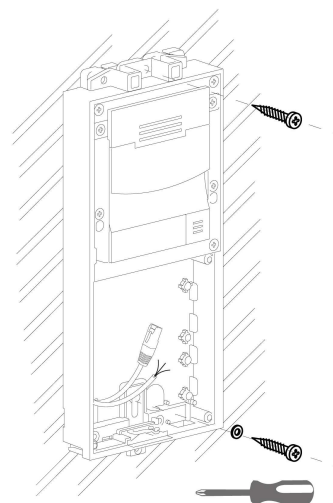
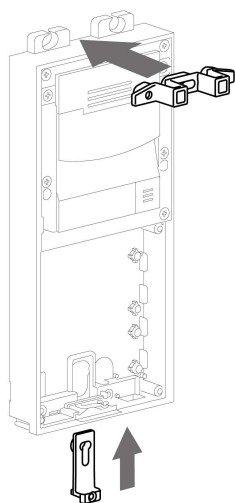

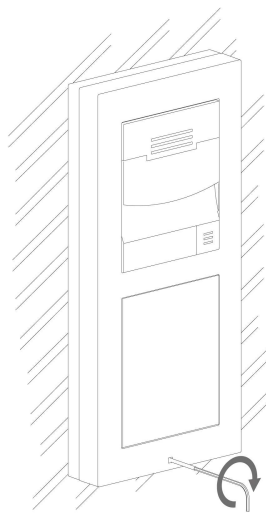
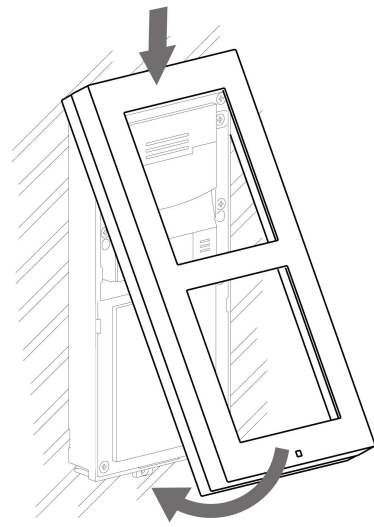
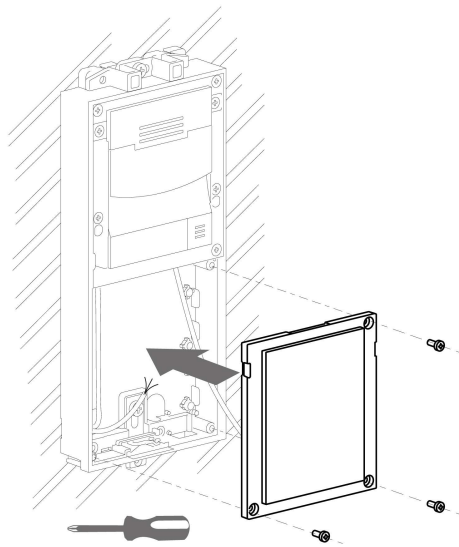

2.2.3 More Two Modules Boxes

Flush mounting box mounting – classics bricks

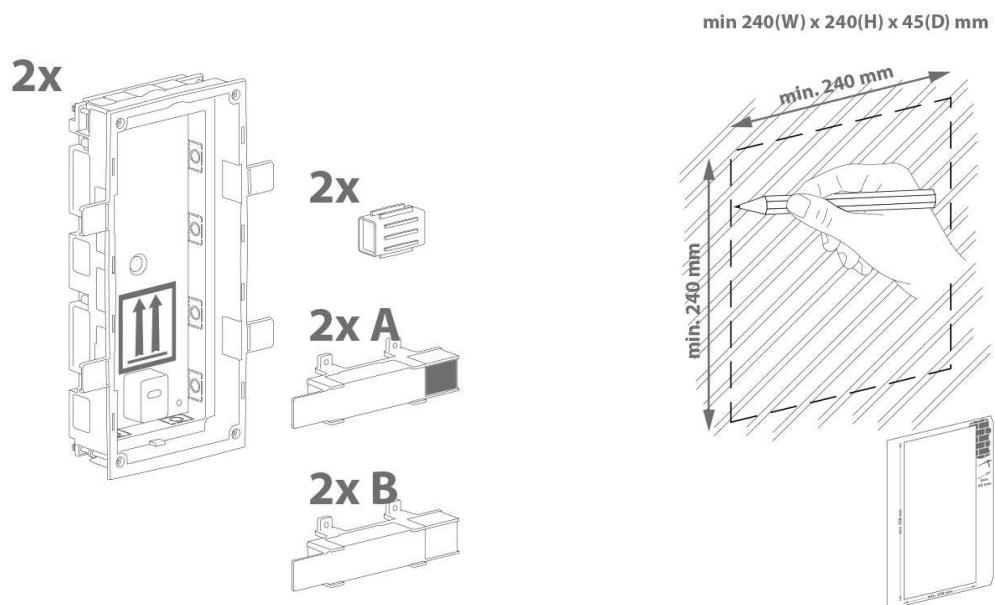

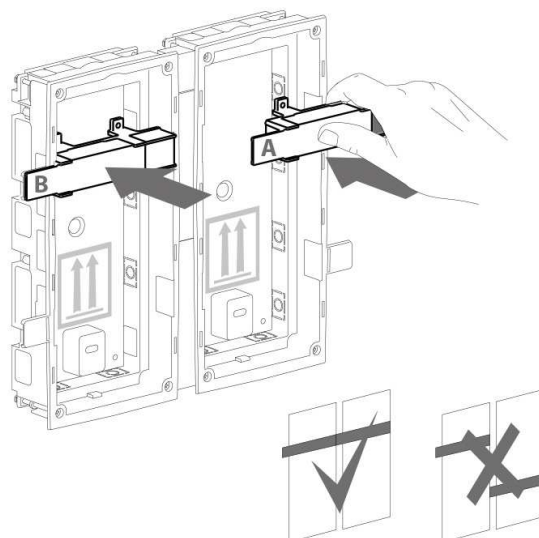
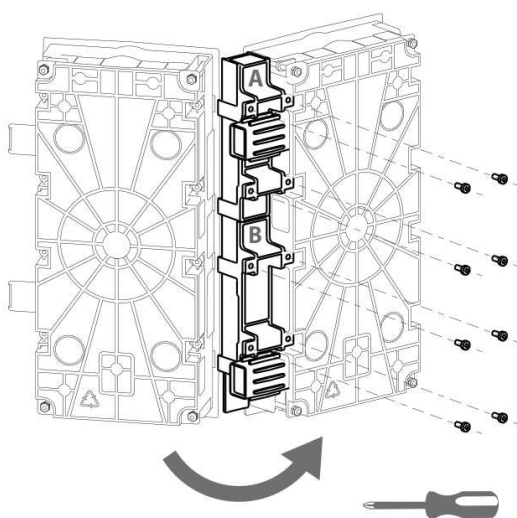
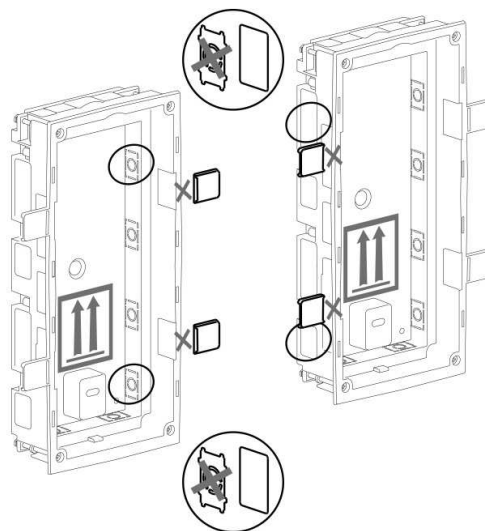
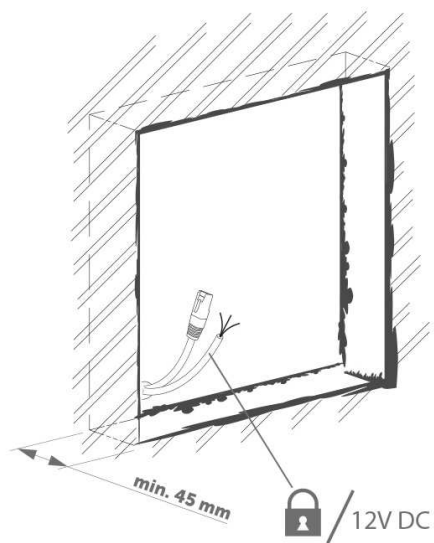

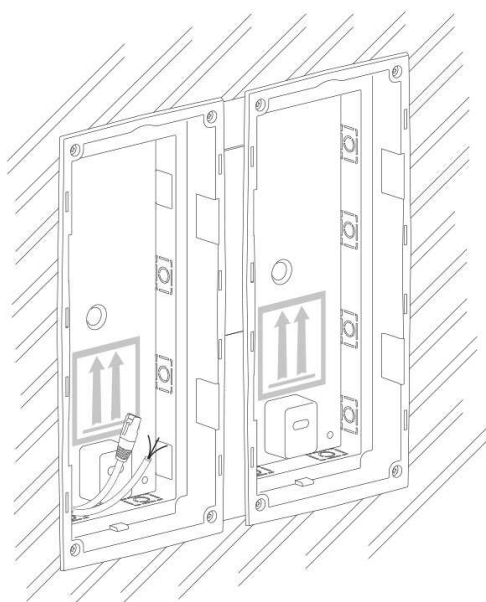
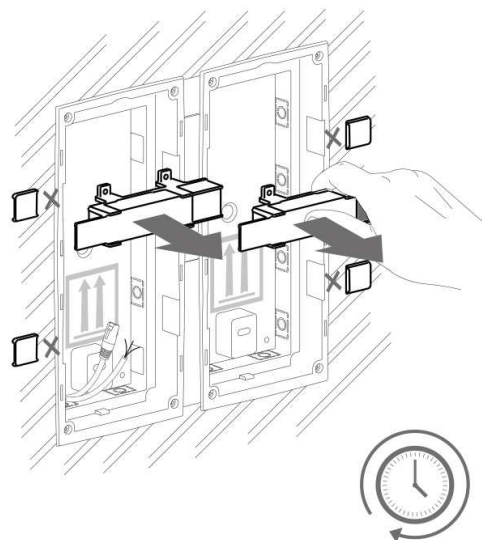
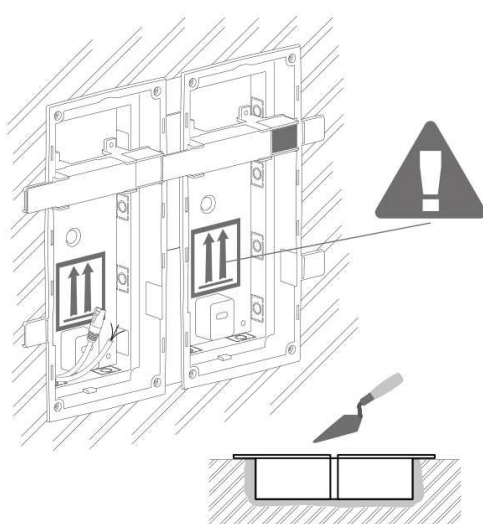

Flush mounting box mounting – plasterboard

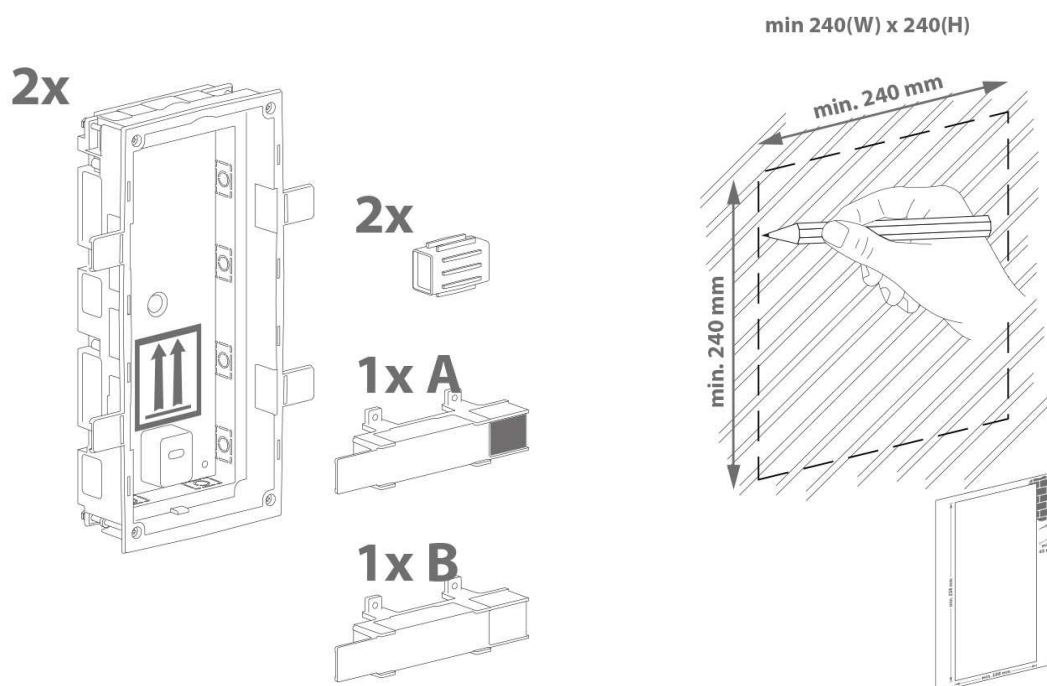

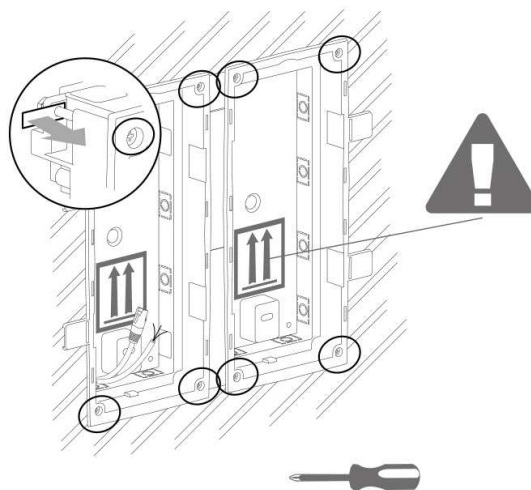
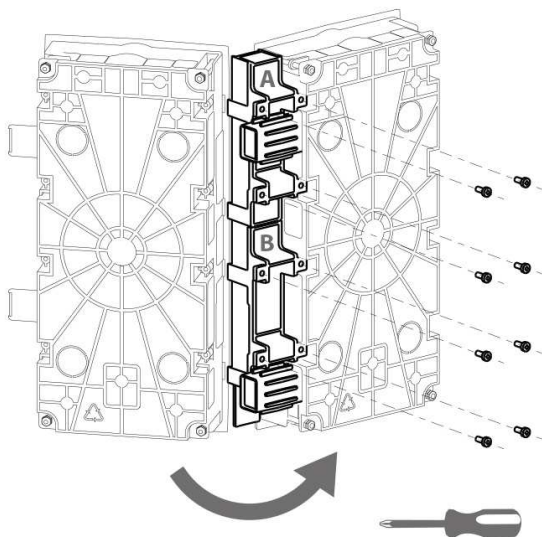
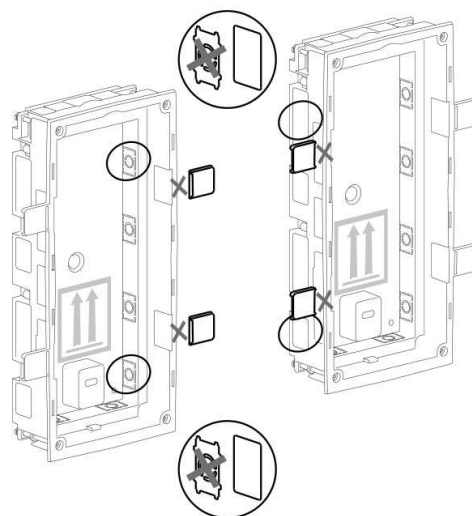
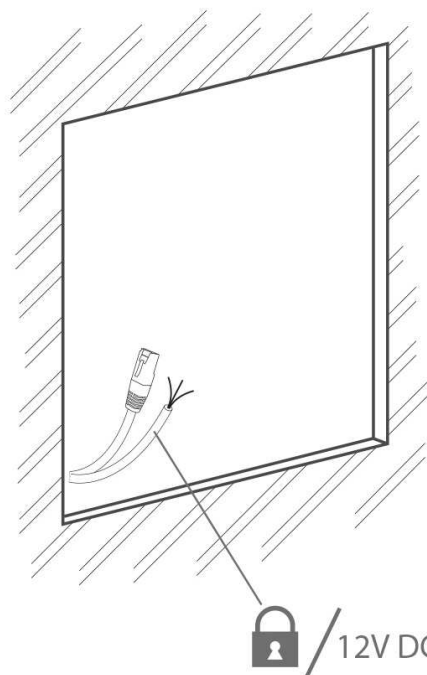

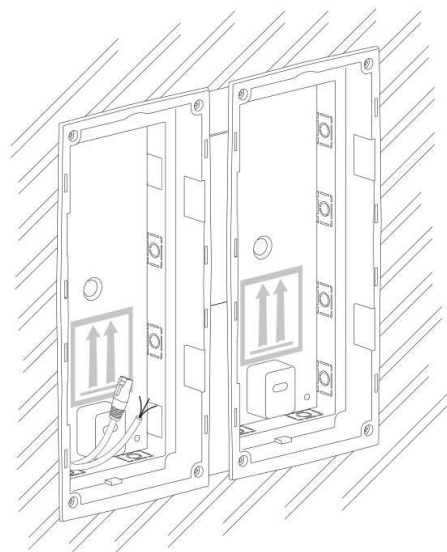
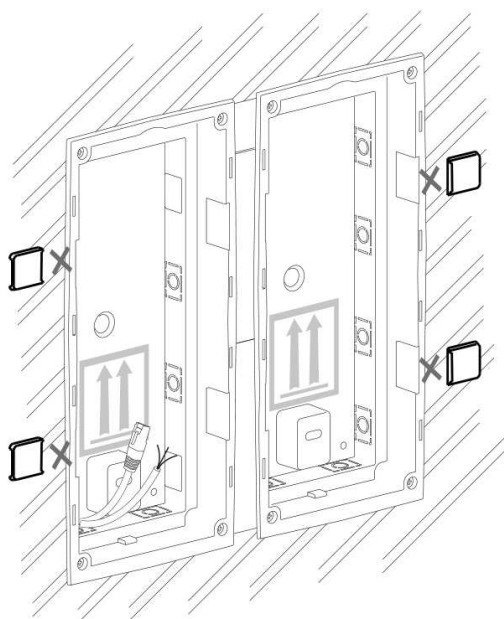

Flush module mounting

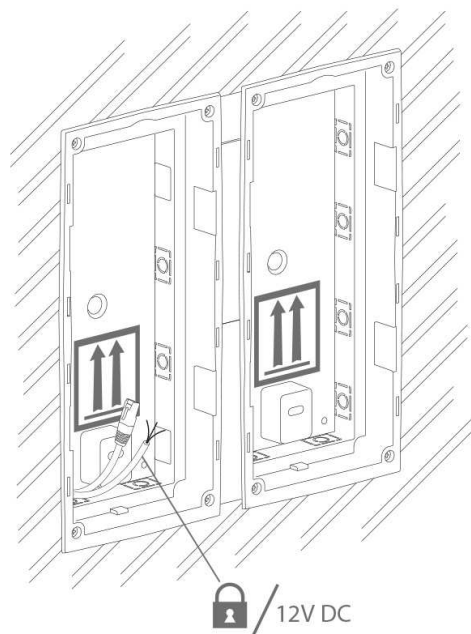
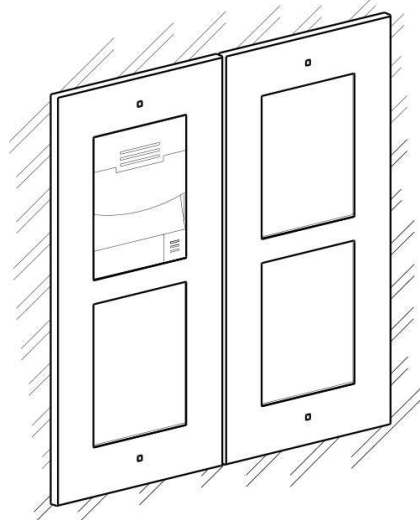

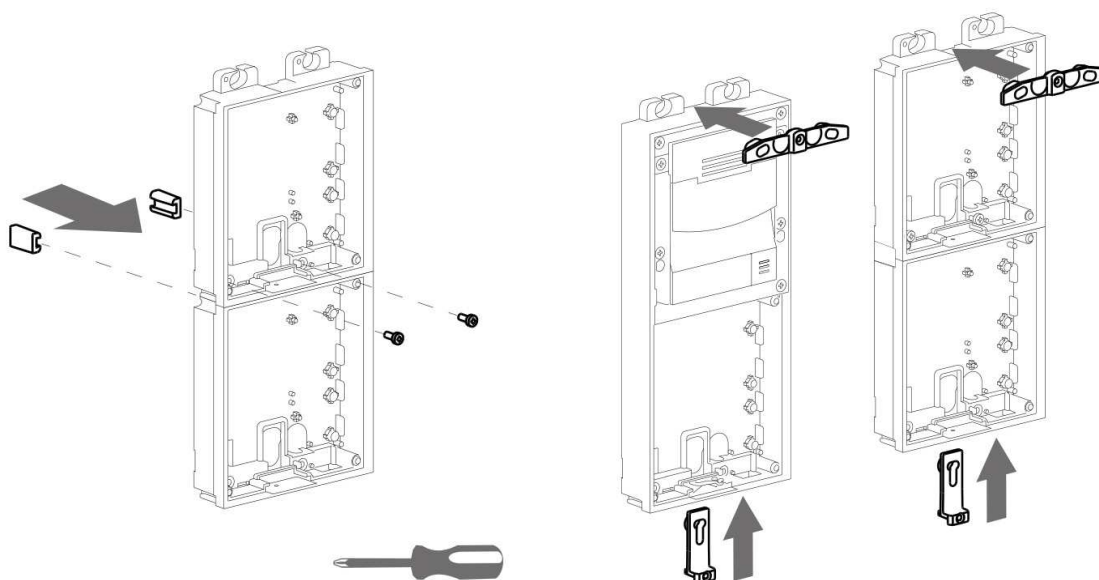
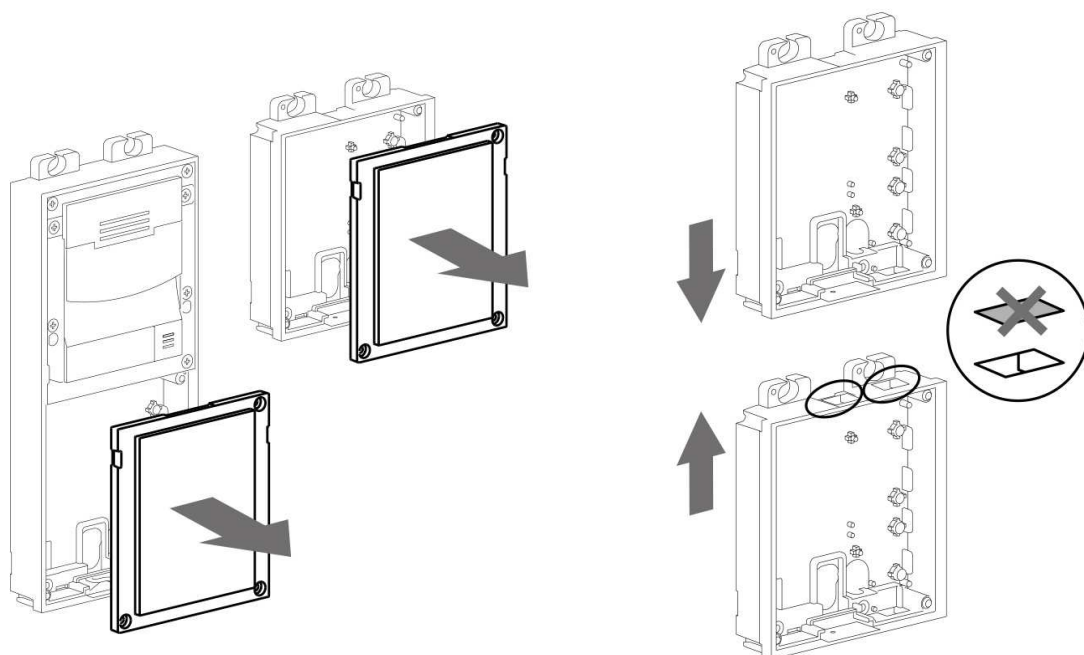

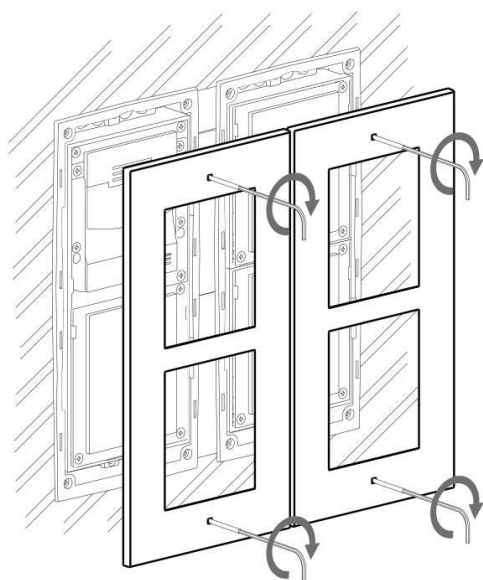
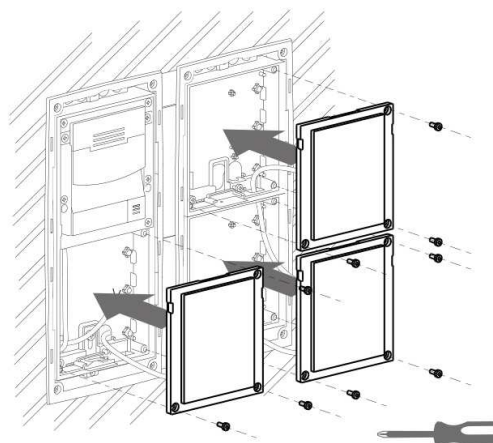
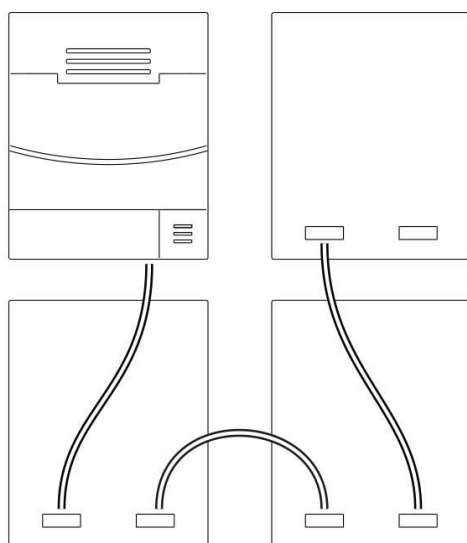

Surface module mounting

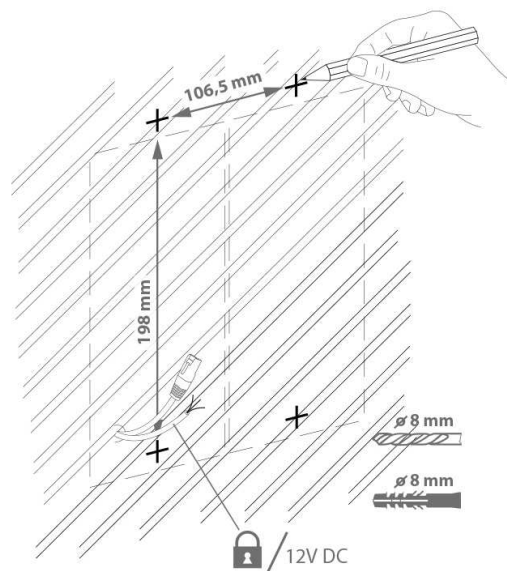
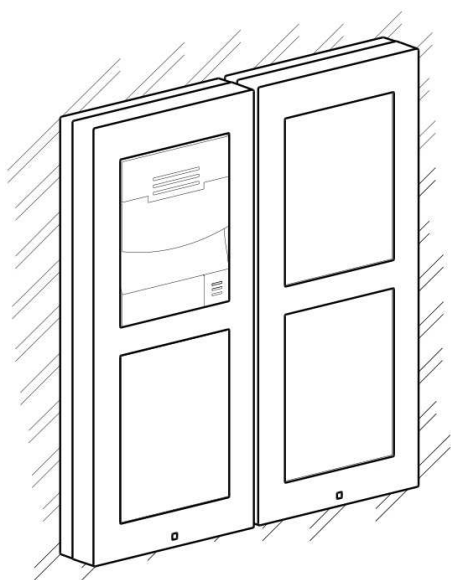

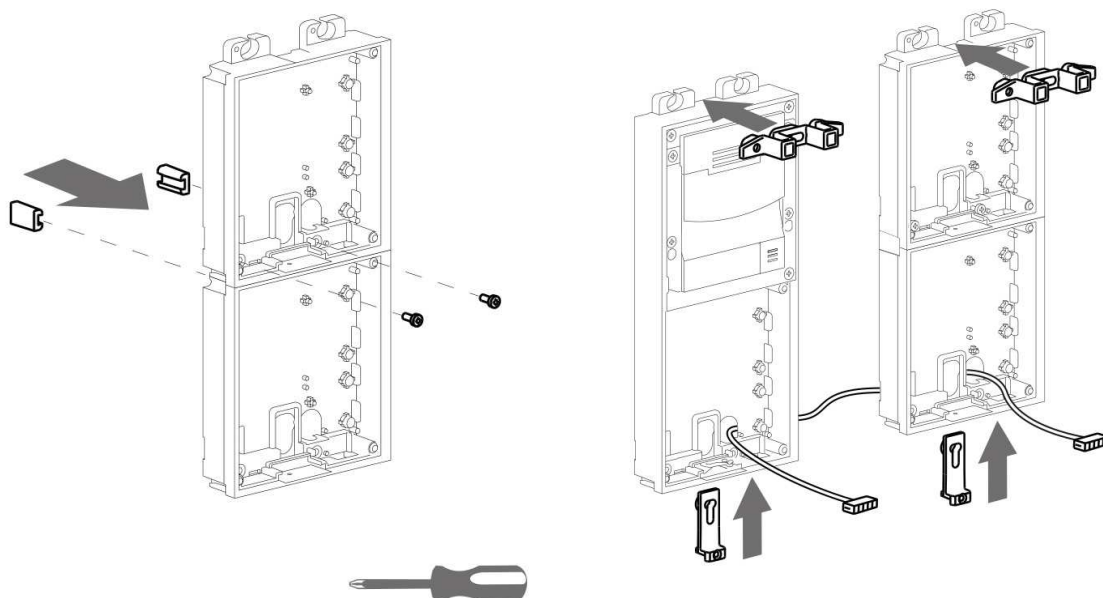
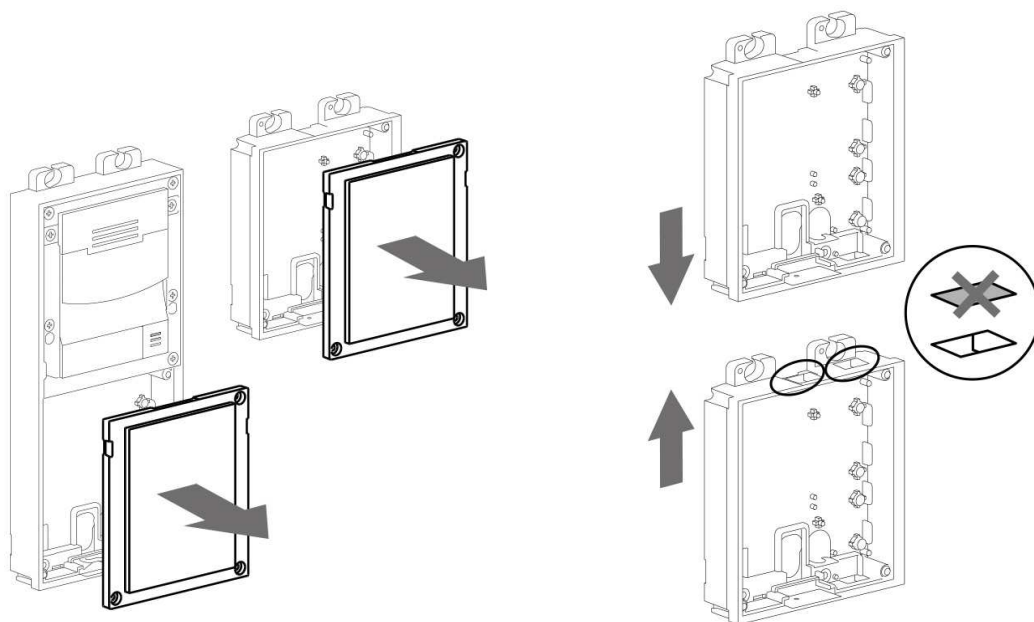

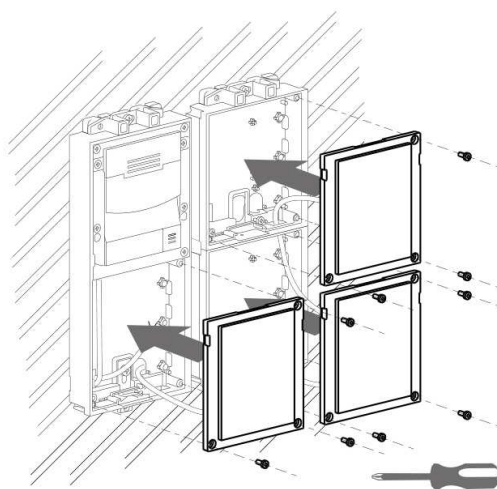
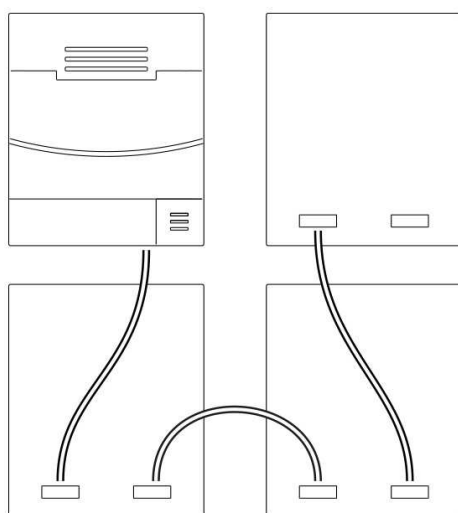
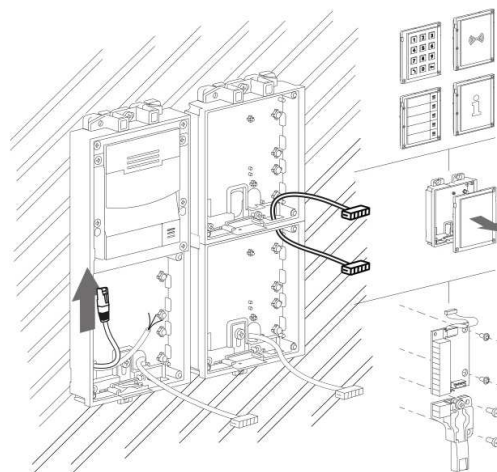
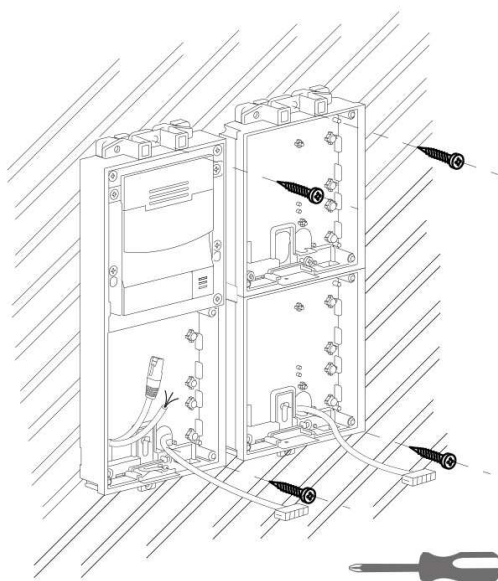

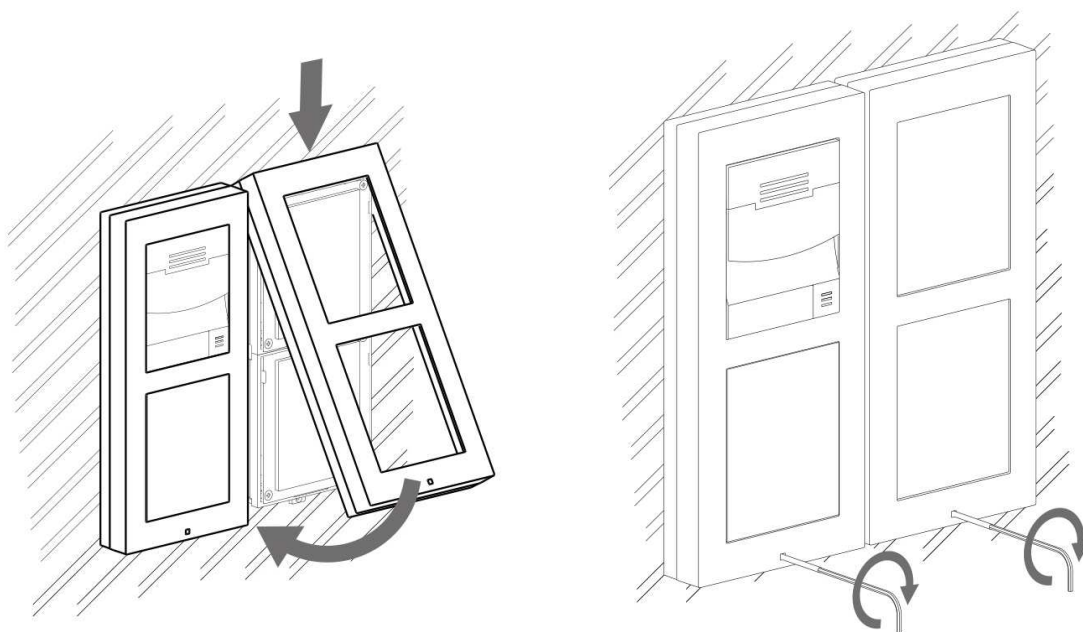

2.2.4 Three Modules Box

Flush mounting box mounting – classics bricks

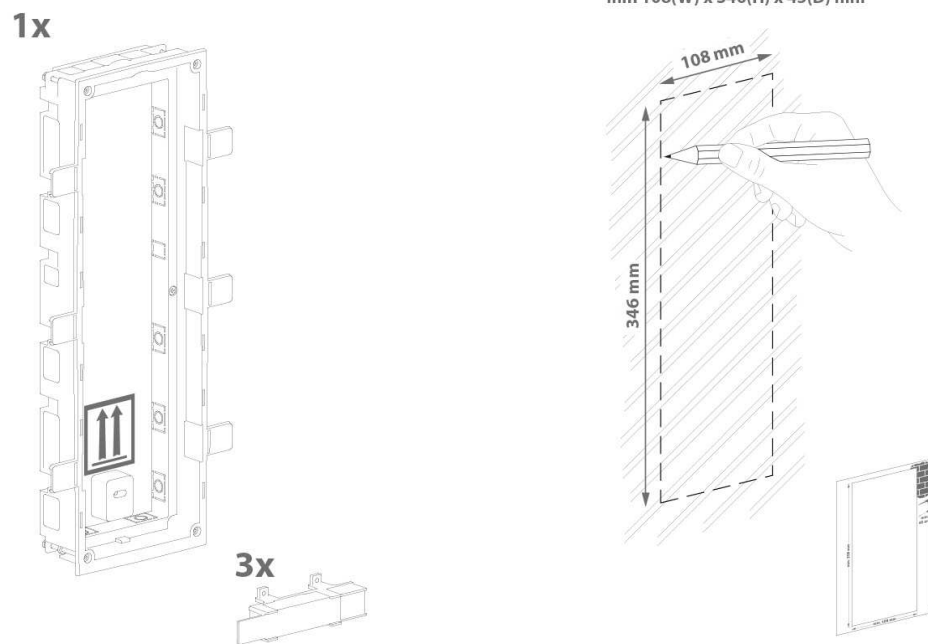

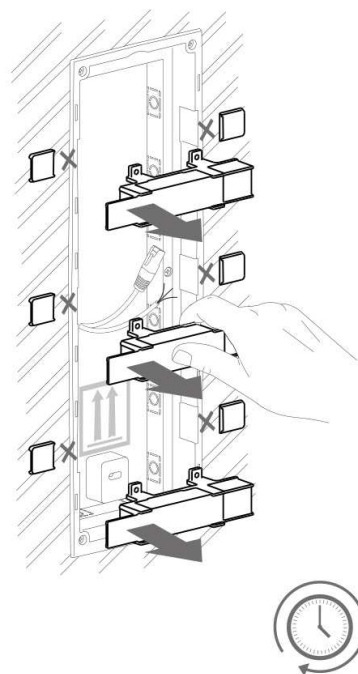
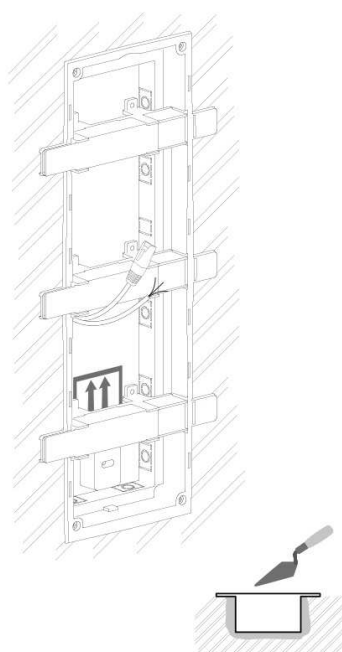
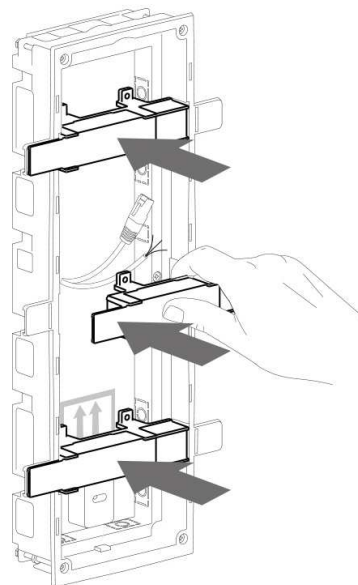
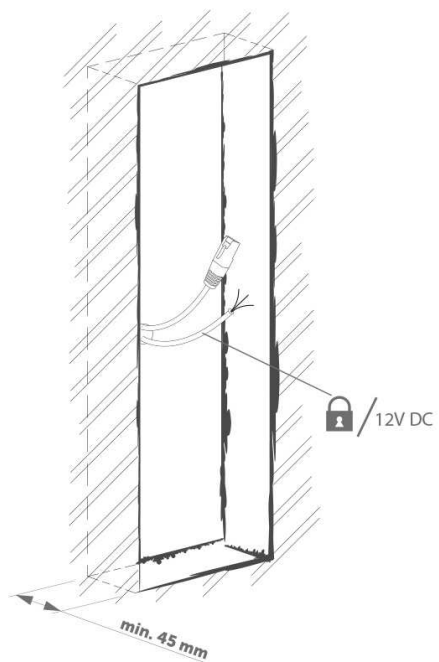

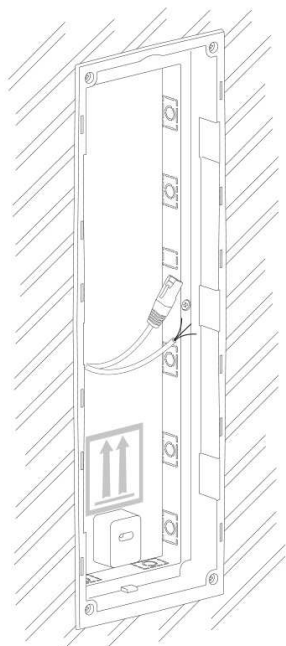

Flush mounting box mounting – plasterboard

1x

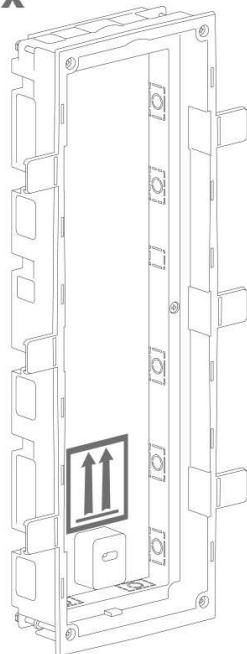

min 108(W) x 346(H) mm

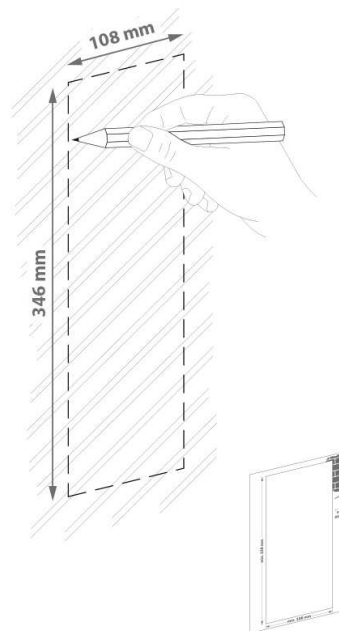

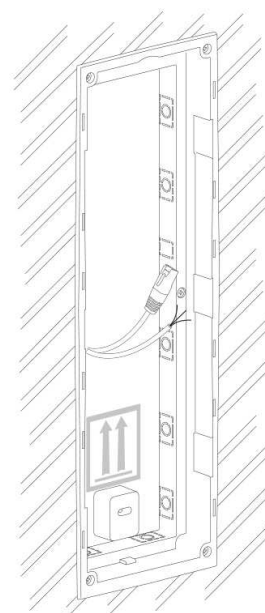
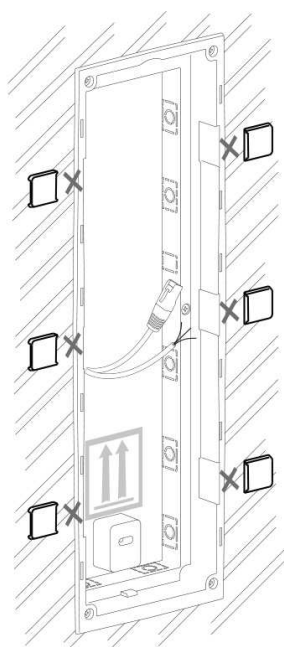
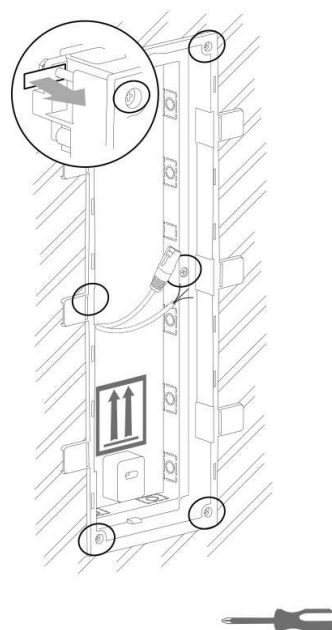
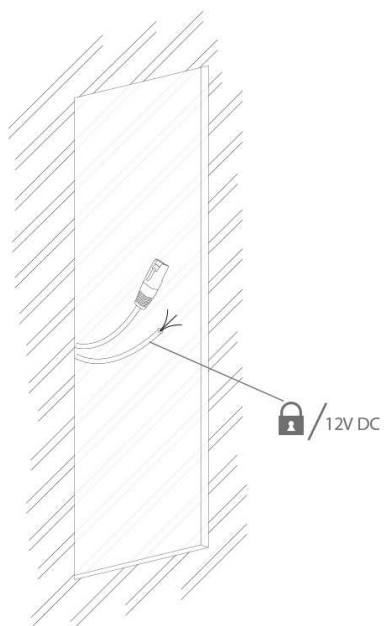

Flush module mounting

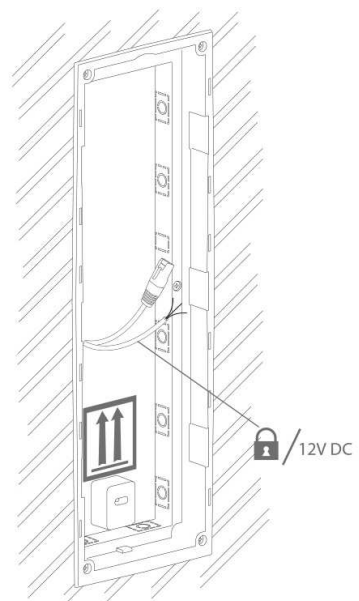
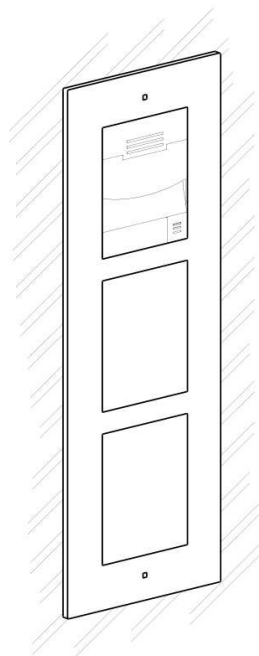

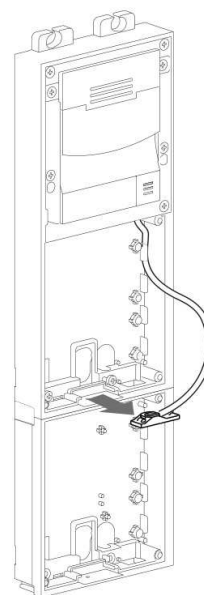
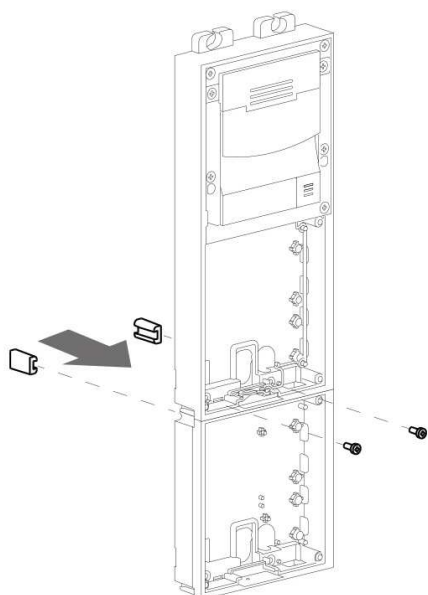
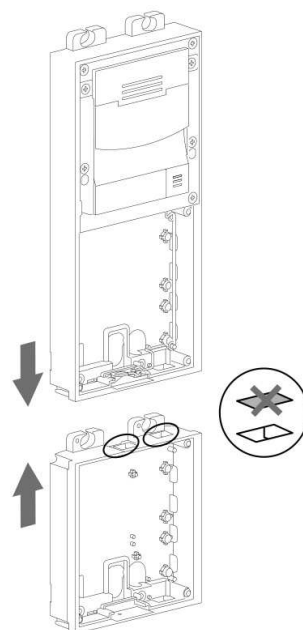
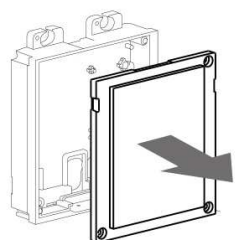
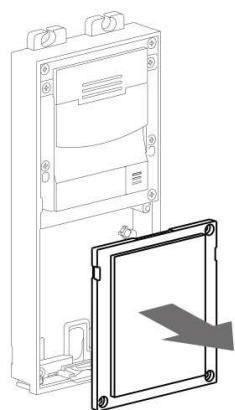

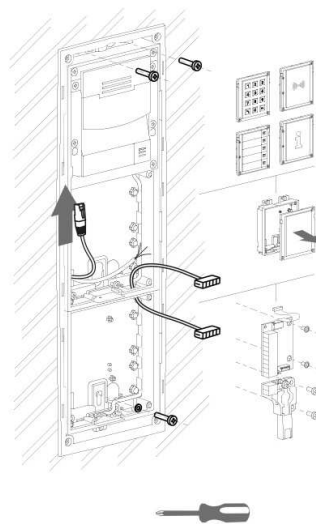
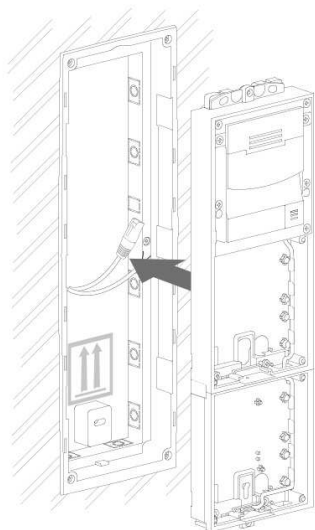
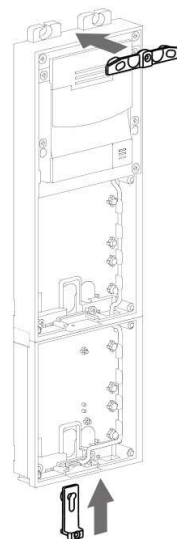
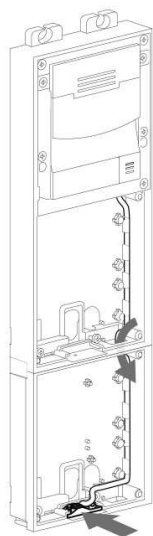

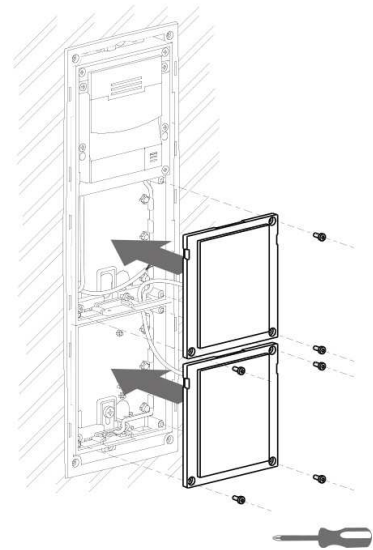
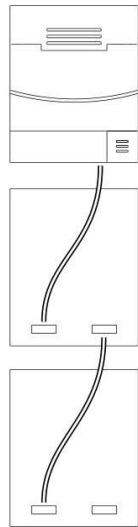

Surface module mounting

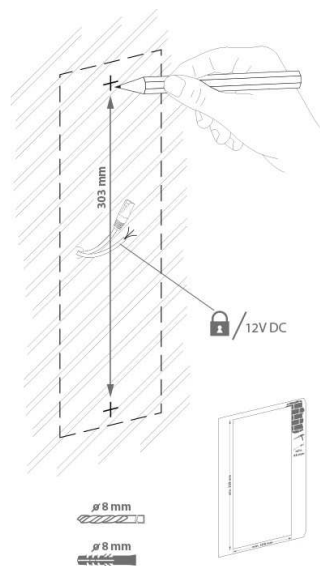
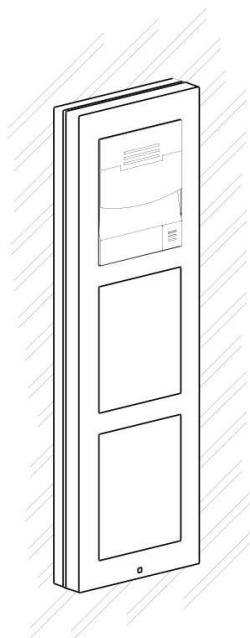

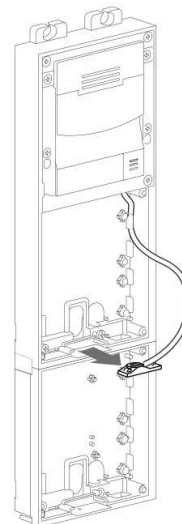
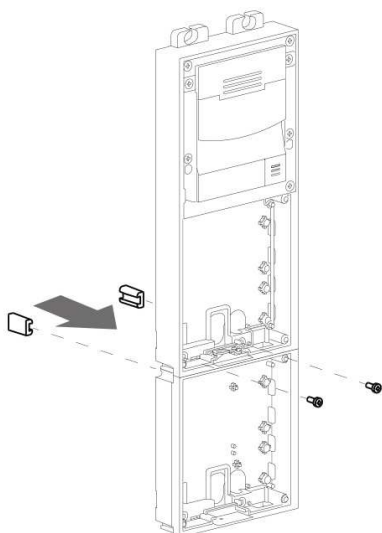
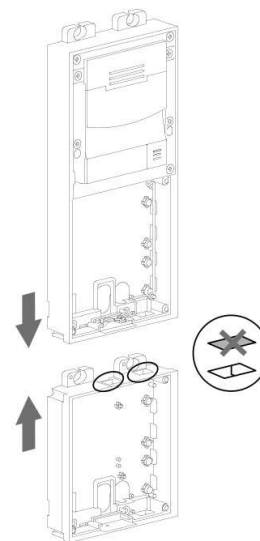
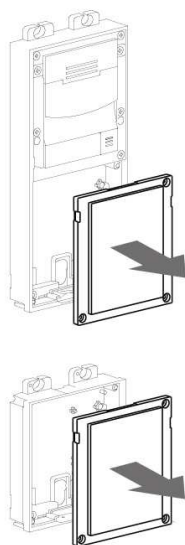

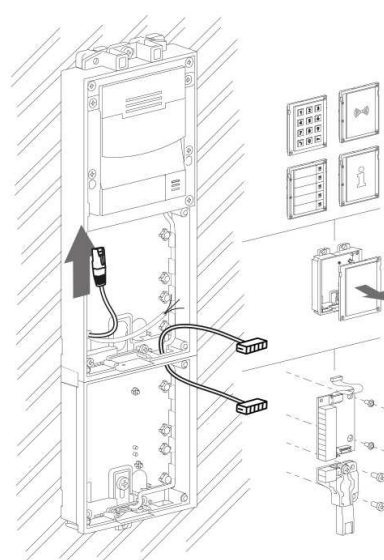
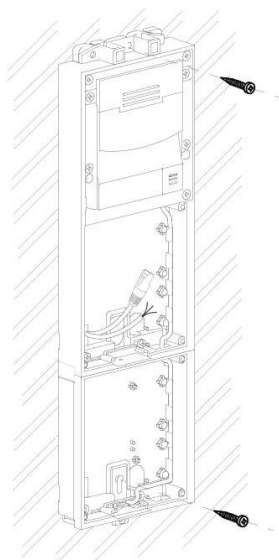
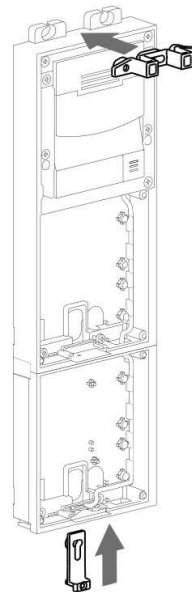
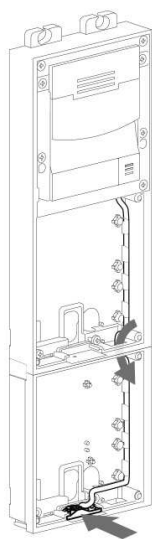

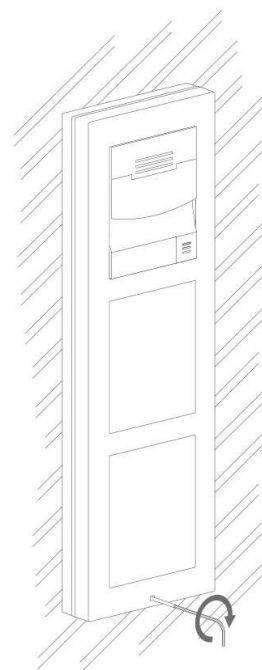
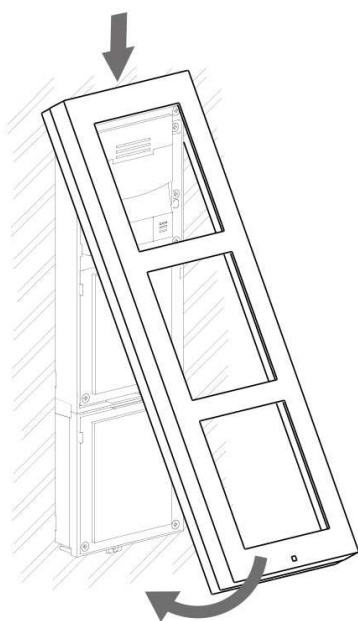
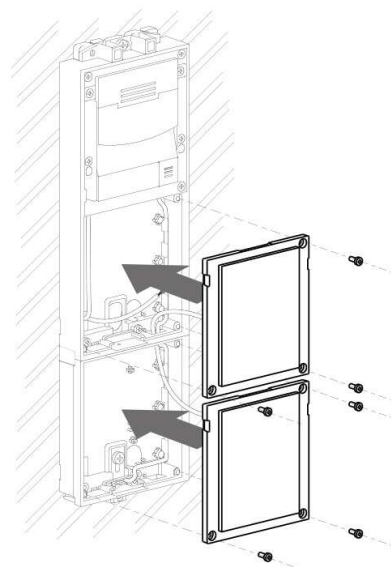
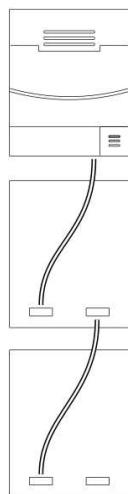

2.2.5 More Three Modules Boxes

Flush mounting box mounting – classics bricks

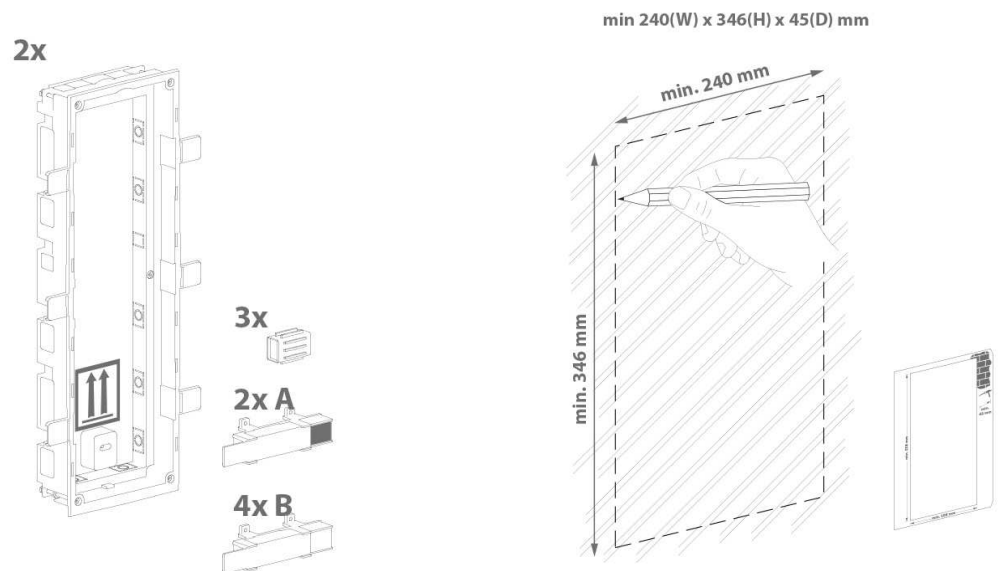

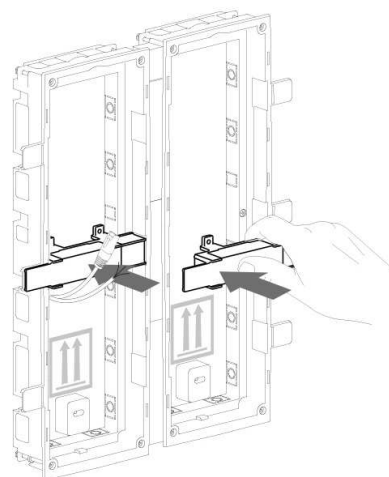
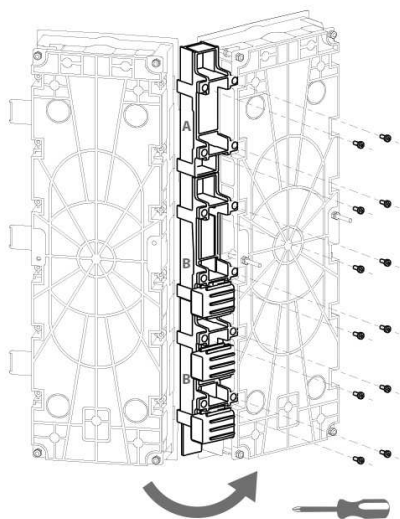
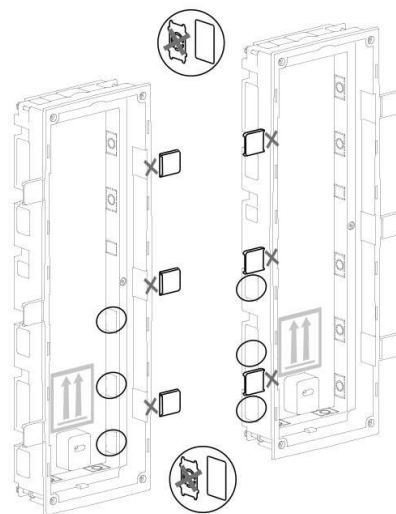
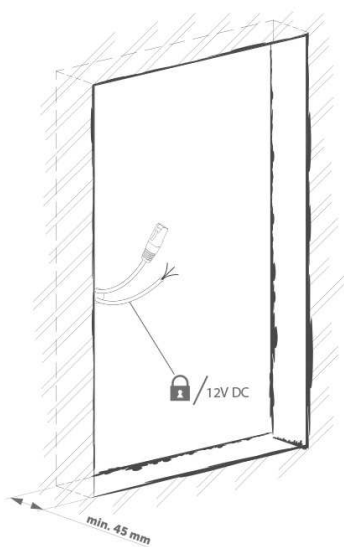

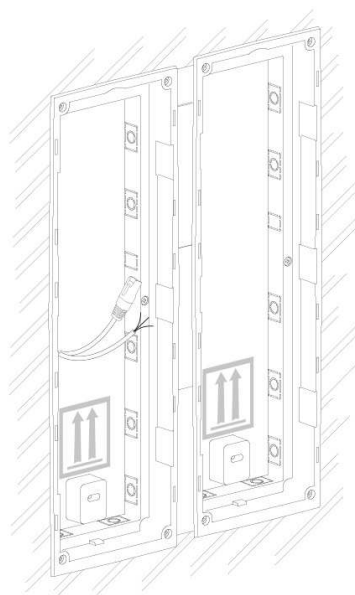
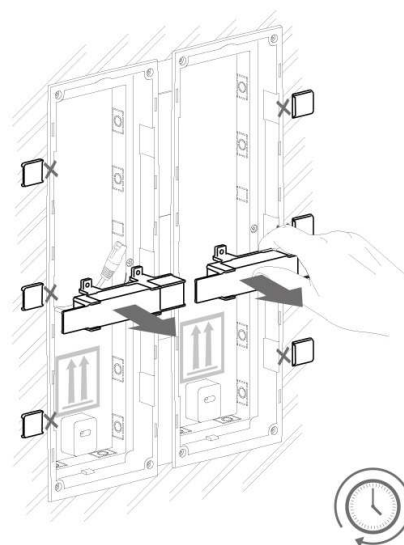
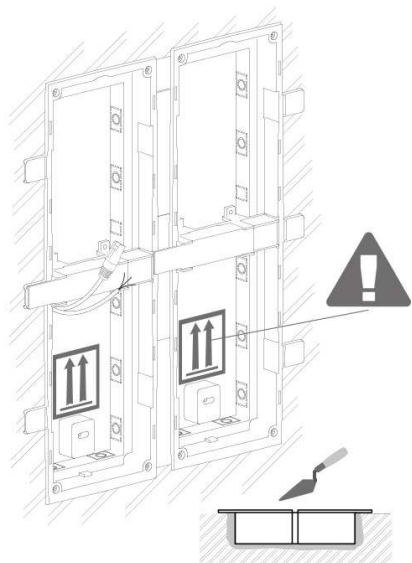

Flush mounting box mounting – plasterboard

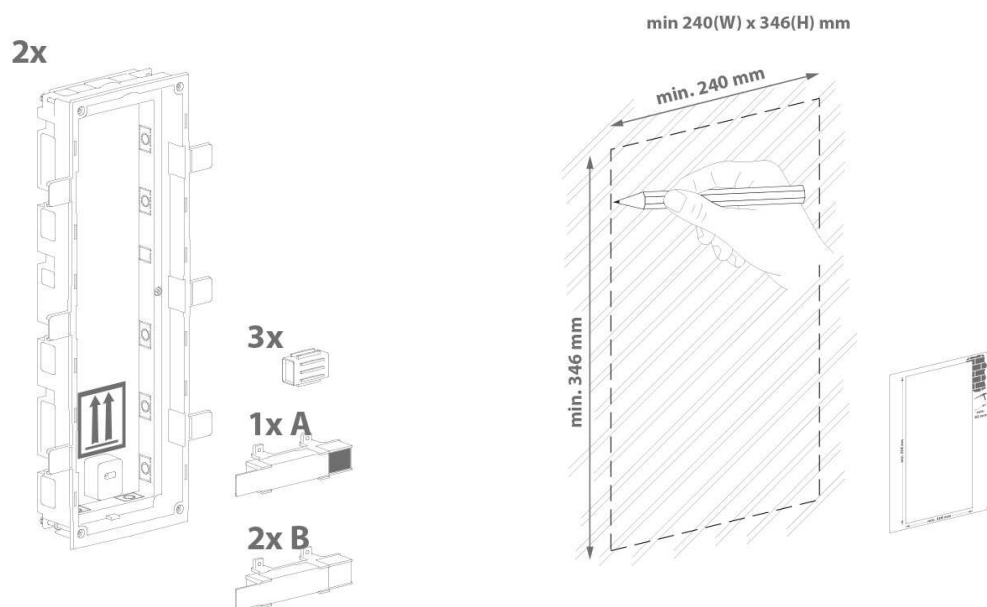

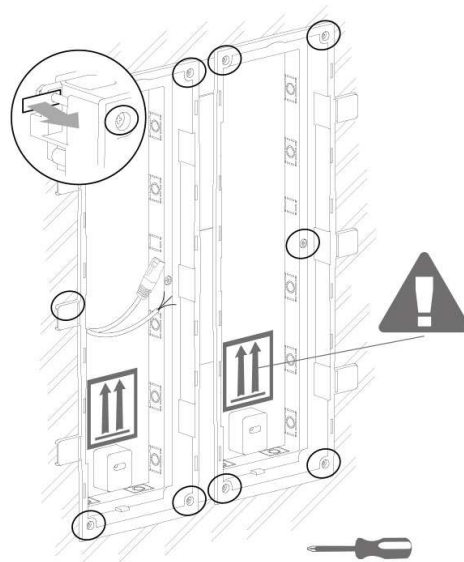
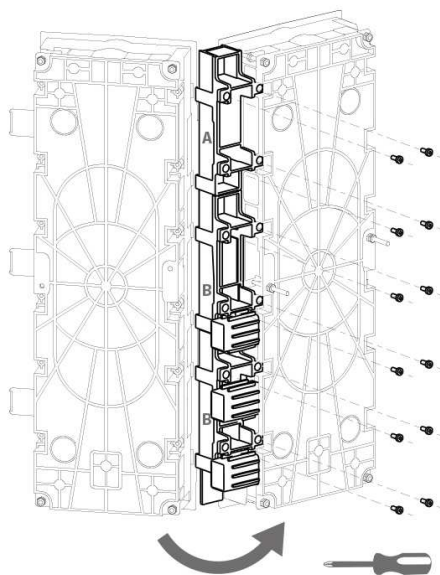
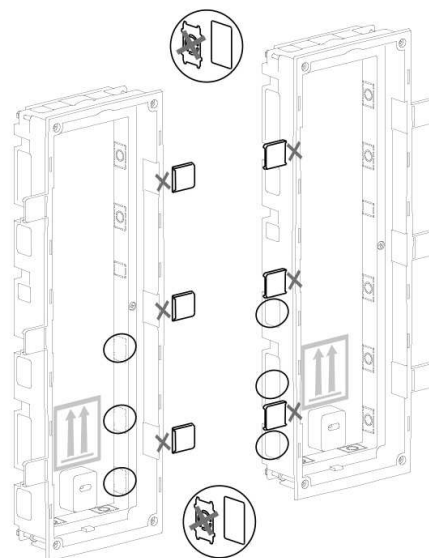
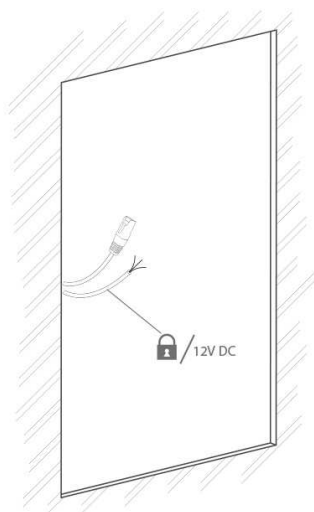

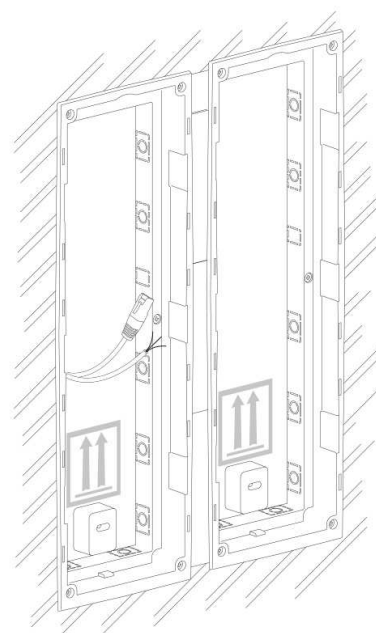
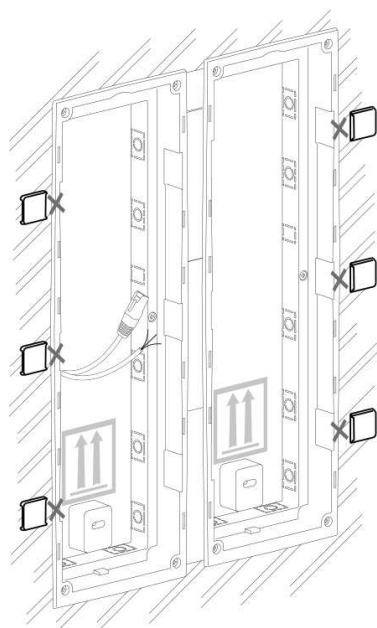

Flush module mounting

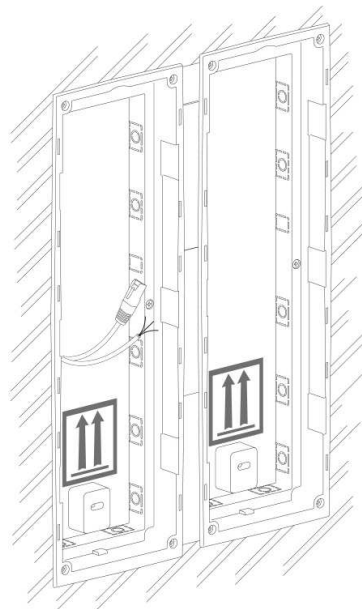
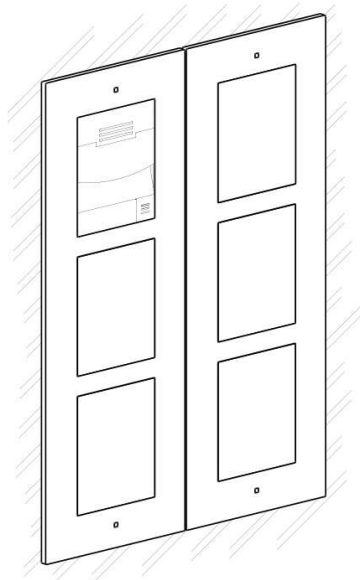

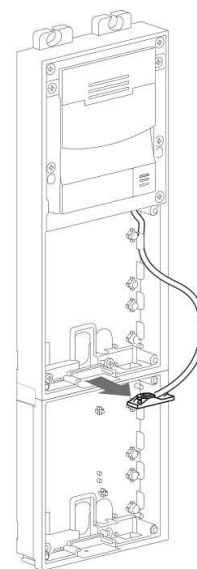
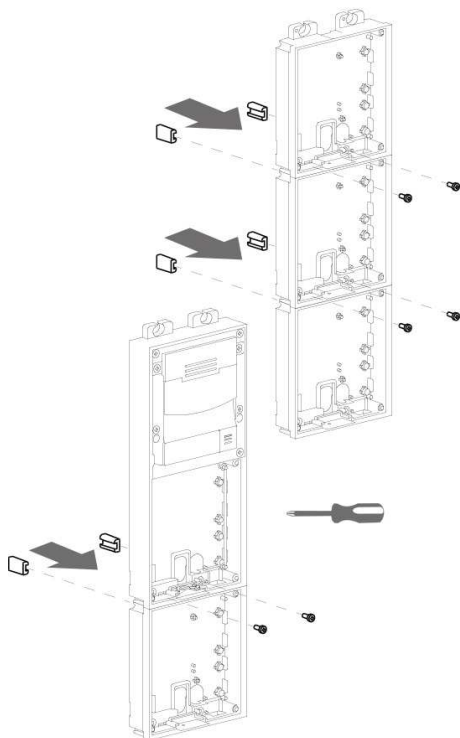
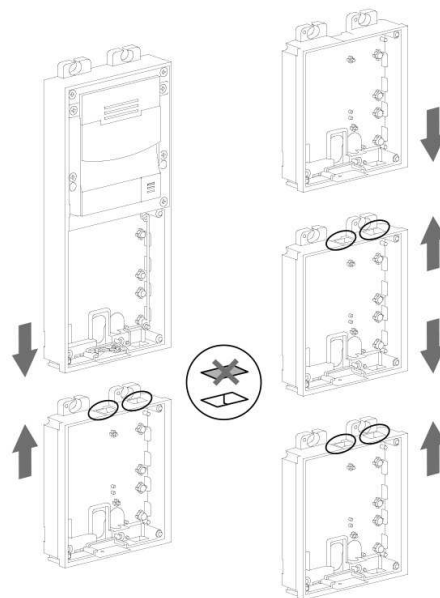
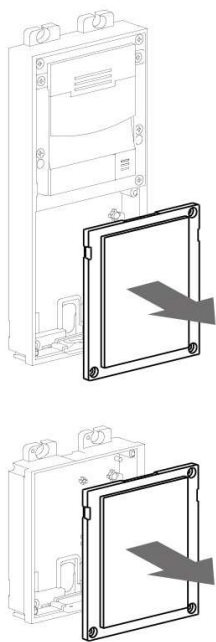

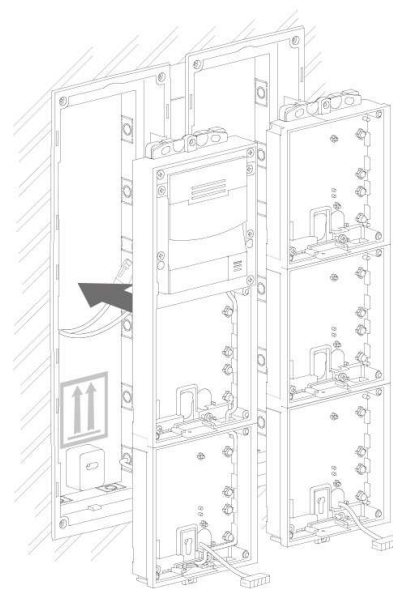
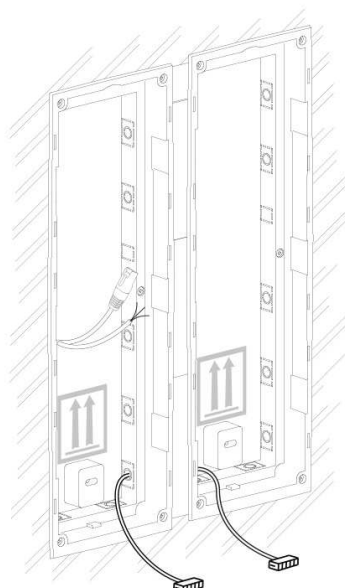
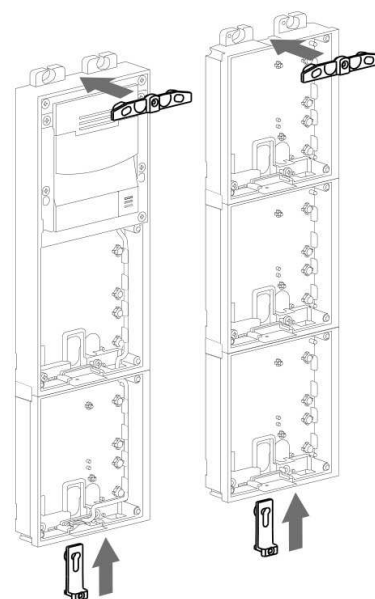
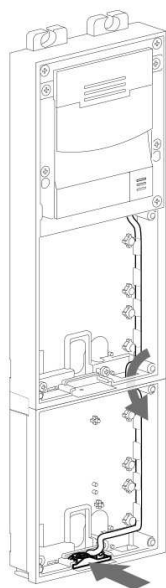

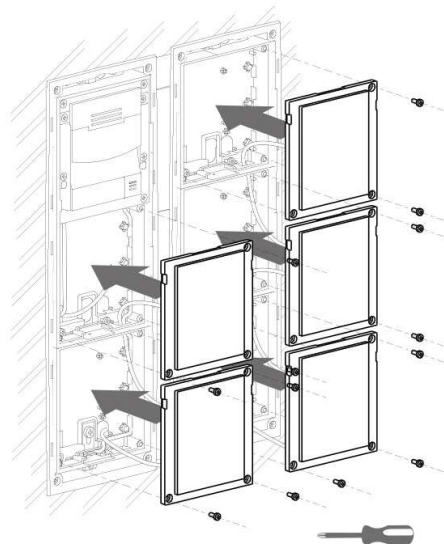
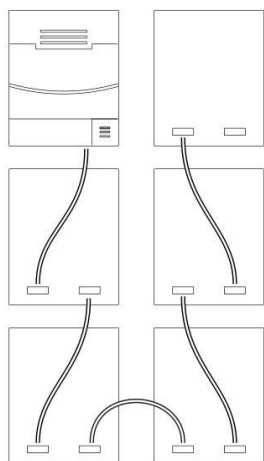
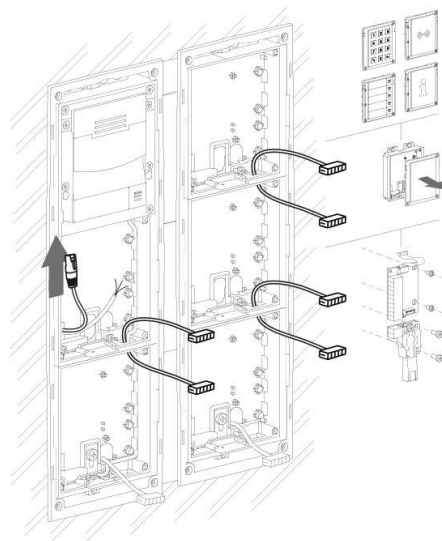
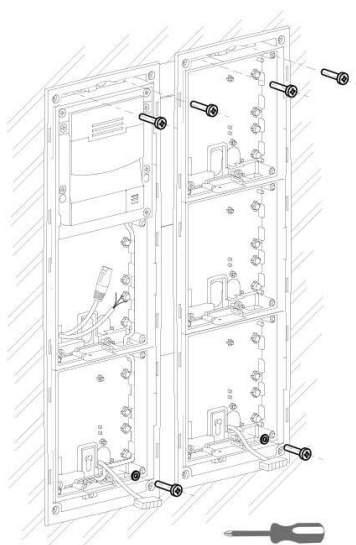

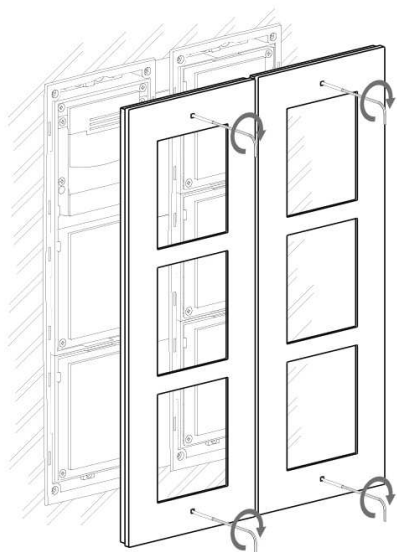

Surface module mounting

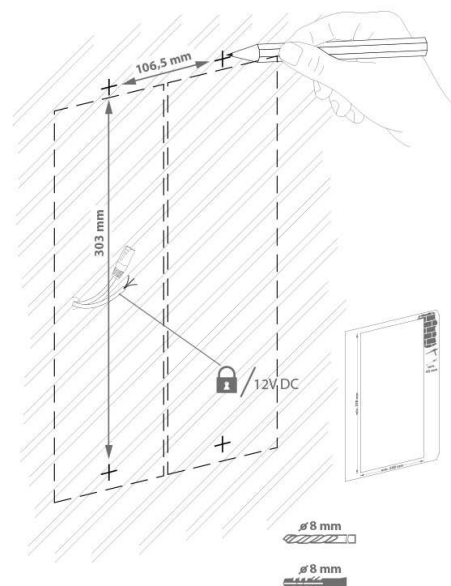

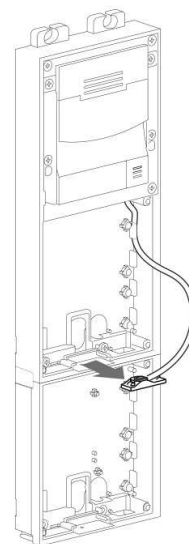
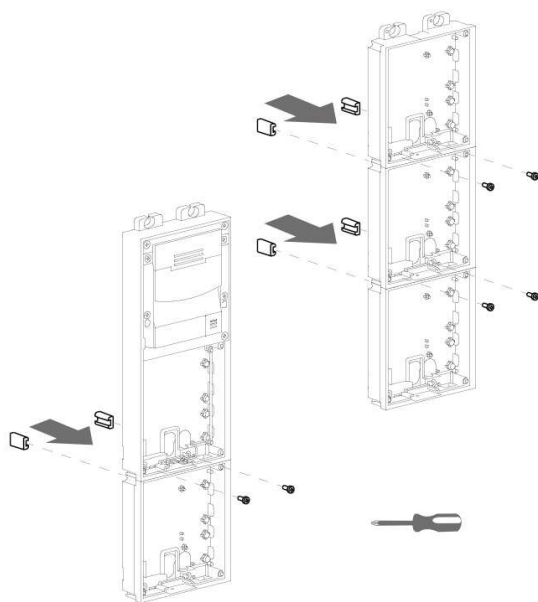
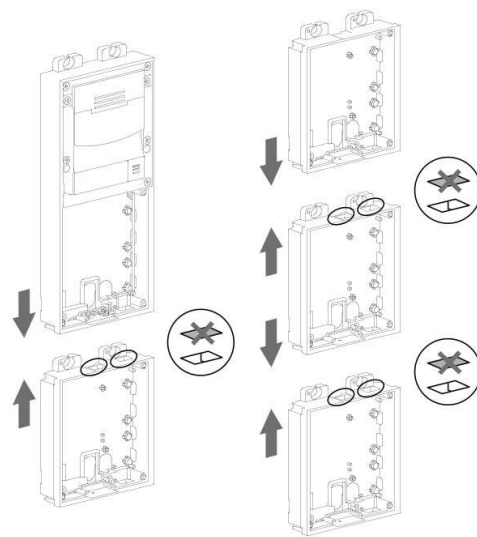
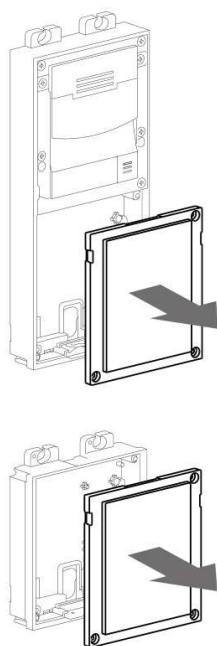

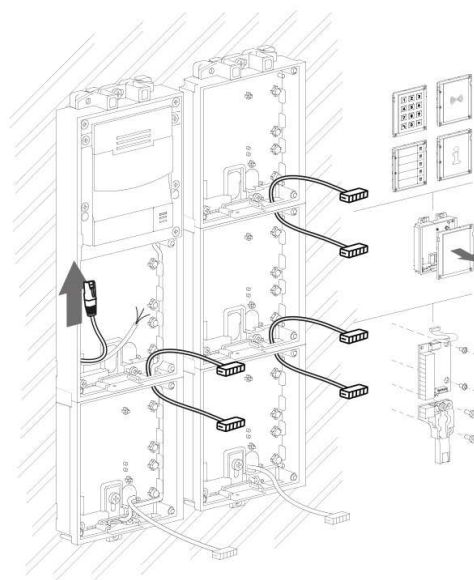
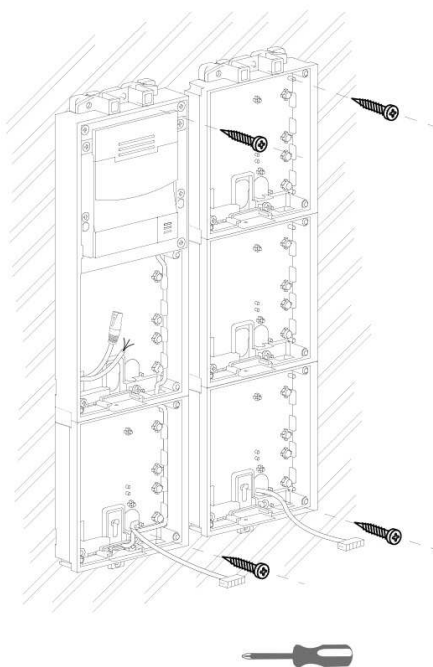
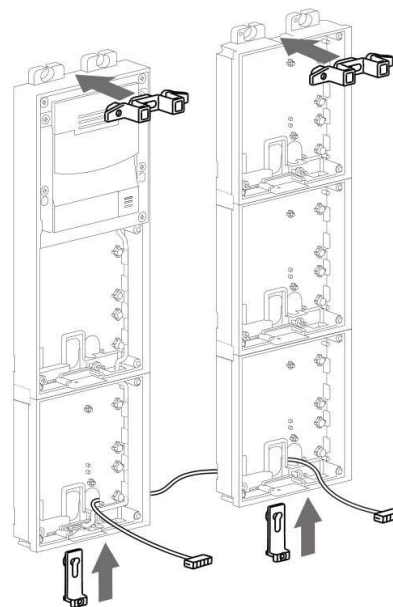
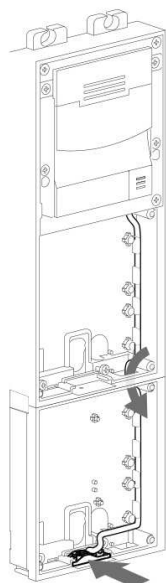

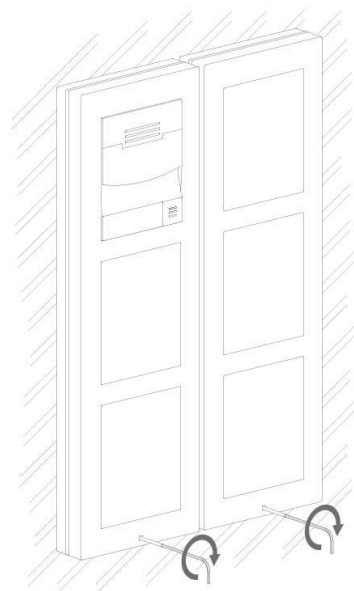
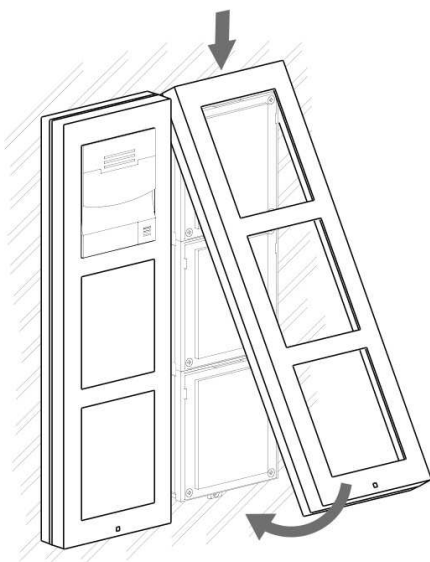
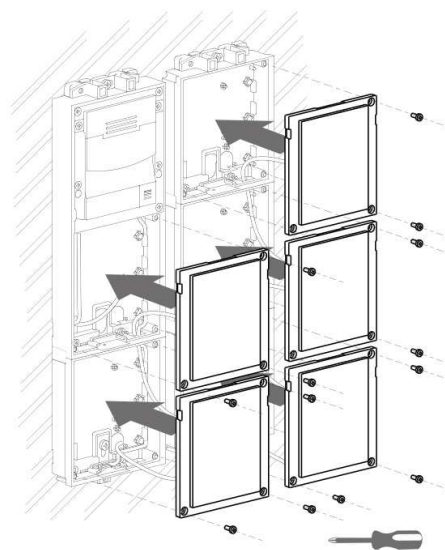
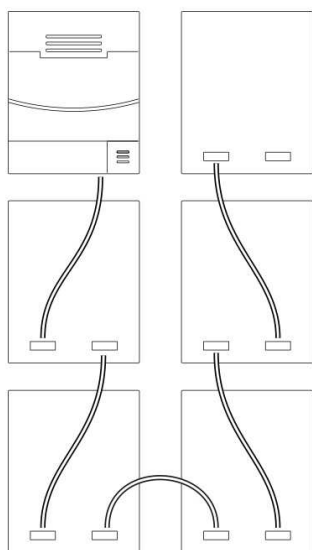

2.2.6 Tamper and I/O Module

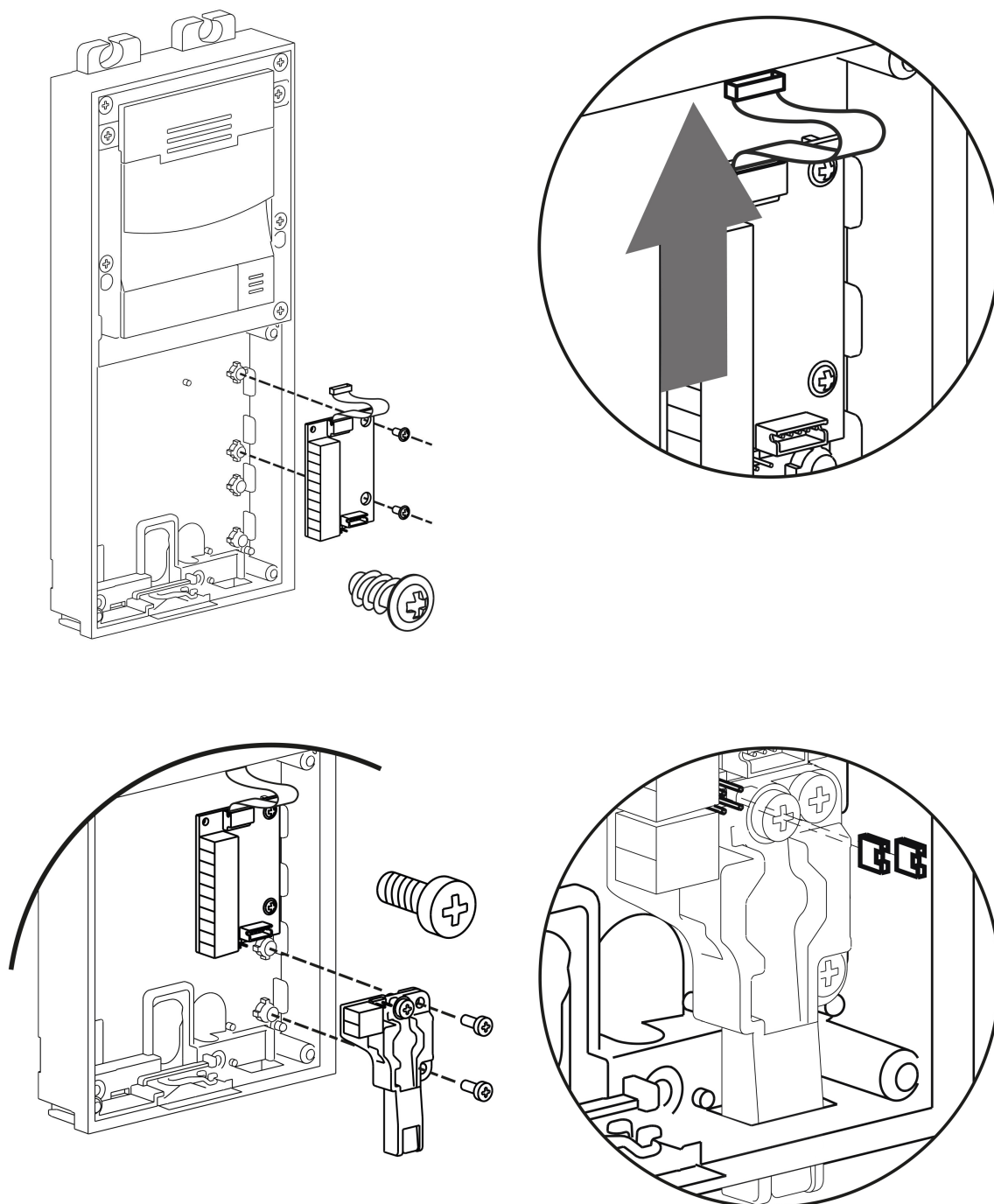

2.3 Electric Installation

This subsection describes how to install the modules, how to connect the **2N® Helios IP Verso** basic unit to the power supply and LAN and how to connect other elements.

Mounting Preparation

1. Unscrew the second module cover on the basic unit base.
2. Use a flat screwdriver to take out the module cover.

Version A – 2-Module Base

1. Place the base on the flush mounting box / predrilled holes with dowels and pull the cables through the bottom holes. Pull the Ethernet cable including the connector through the bottom hole to the left if necessary.
2. Insert the metal fitting elements up and down and screw the base plate tight. You can level the base slightly if you are mounting just one base.

Version B – 3-Module Base

1. Unscrew the cover of the additional base.
2. Use a flat screwdriver to take out the cover.
3. Slide the additional base to the basic unit base and secure its position with the small side wedges and screws.
4. Remove the microphone from the basic unit base and loosen the microphone cable.
5. Lead the microphone to the third module base as shown in the figure.
6. Place the joined bases on the flush mounting box / predrilled holes with dowels and pull the cables through the bottom holes. Feed the Ethernet cable without the connector from the additional base to the basic unit base if necessary.

Version C – Additional Columns

1. Unscrew the cover of the additional bases and take it out with a flat screwdriver.
2. Insert the bases into each other as projected and secure their position with the small side wedges and screws.
3. Place the cover on the flush mounting box / predrilled holes with dowels and pull the cables if any through the bottom holes.
4. Pull the bus using the cable bushing available in the flush mounting box.

Basic Unit

Power Supply Connection

2N® Helios IP Verso can be powered either from an external 12 V / 2 A DC source or directly from the LAN equipped with PoE 802.3af supporting network elements. Owing to different power outputs, the power supply selection affects the maximum count and applicability of the modules connected of the basic unit.

External power supply

Use a 12 V $\pm 15\%$ SELV supply dimensioned to the minimum current consumption of 2 A (Part No. 91341481E) to make your system work reliably. This power supply provides **2N[®] Helios IP Verso** with 24 W for feeding of the basic unit and connected modules.

PoE Power Supply

2N[®] Helios IP Verso is compatible with the PoE 802.3af (Class 0 – 12,95 W) technology and can be fed directly from the LAN via the compatible network elements. If your LAN does not support this technology, insert a PoE injector, Part No. 91378100, between **2N[®] Helios IP Verso** and the nearest network element. This power supply provides **2N[®] Helios IP Verso** with 12 W for feeding of the basic unit and connected modules.

Combined Power Supply

2N[®] Helios IP Verso can be fed from an external power supply and PoE at the same time. In this configuration, the maximum power for the connected modules is available.

LAN Connection

2N[®] Helios IP Verso is connected to the Local Area Network (LAN) via the UTP/STP cable (Cat 5e or higher) terminated with an RJ-45 (LAN) connector. As the device is equipped with the Auto-MDIX function, both the straight and crossed cable can be used.

Basic Unit Connector Configuration

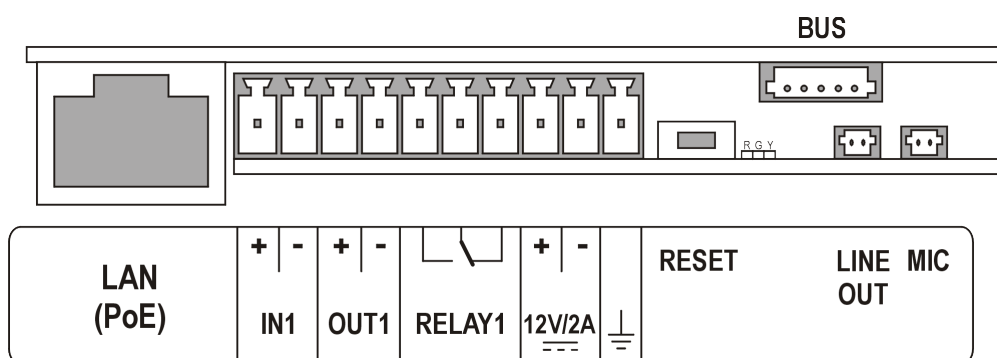

Legend	
LAN (PoE)	LAN (PoE according to 802.1af) connector
IN1	IN1 terminals for input in passive/ active mode (−30 V to +30 V DC) OFF = open OR $U_{IN} > 1.5 \text{ V}$ ON = closed contact OR $U_{IN} < 1.5 \text{ V}$
OUT1	OUT1 terminals of active input for 2N® Helios IP Security Relay or electric lock connection 8 up to 12 V DC depending on power supply (PoE: 10 V; adaptor: power supply voltage minus 2 V), max 400 mA
RELAY1	RELAY1 terminals with accessible 30 V / 2 A AC/DC NO/NC contact
12V/2A	External 12 V / 2 A DC supply terminals
GND	Grounding terminal
RESET	RESET / FACTORY RESET button
RGY	LED indicators (red/green/yellow)
LINE OUT	LINE OUT connector (1 V_{RMS})
MIC	MIC connector for microphone connection
BUS	2N® Helios IP Verso bus connector

Device Restart

Press the RESET button shortly to restart the device.

Factory Reset

2N® Helios IP Verso is equipped with a RESET button. Press the button shortly (< 1 s) to restart the system without changing configuration.

Follow the instructions below to **identify the current IP address**:

- Press and hold the RESET button.
- Wait until the red and green LEDs on the device come on simultaneously (approx. 20 s).
- Release the RESET button.
- The device announces the current IP address via the loudspeaker connected automatically.



Follow the instructions below to switch on the **Static IP address** mode (DHCP OFF):

- Press and hold the REST button.
- Wait until the red and green LEDs on the device come on simultaneously (approx.

- 20 s).
- Wait until the red LED goes off (approx. 5 s).
- Release the RESET button.

The following network parameters will be set after restart:

- IP address: 192.168.1.100
- Network mask: 255.255.255.0
- Default gateway: 192.168.1.1

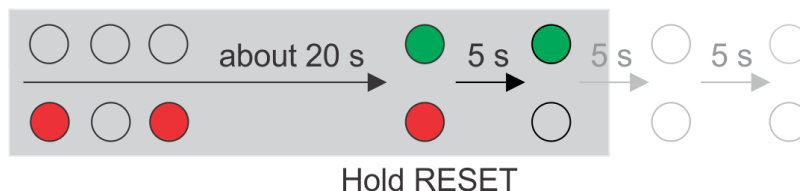

Follow the instructions below to switch on the **Dynamic IP address** mode (DCHP ON):

- Press the RESET button.
- Wait until the red and green LEDs on the device come on simultaneously (approx. 20 s).
- Wait until the red LED goes off (approx. 5 s).
- Wait until the green LED goes off and the red LED comes on again (another 5 s).
- Release the RESET button.

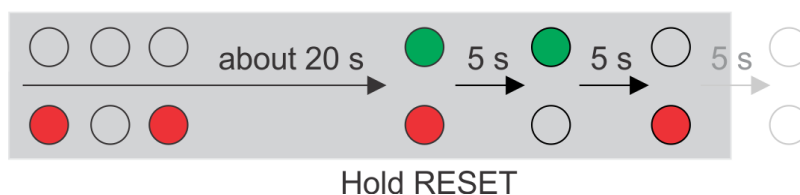

Follow the instructions below to **reset the factory default values**:

- Press the RESET button.
- Wait until the red and green LEDs on the device come on simultaneously (approx. 20 s).
- Wait until the red LED goes off (approx. 5 s).
- Wait until the green LED goes off and the red LED comes on again (approx. 5 s).
- Wait until the red LED goes off (another 5 s).
- Release the RESET button.

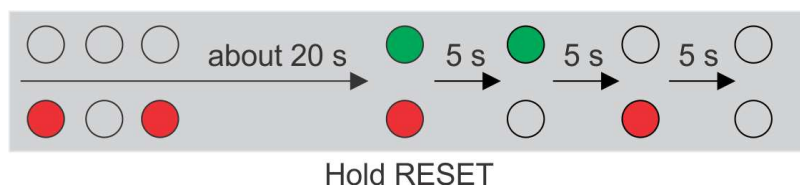

Available Switches

Location	Name	Description
Basic Unit	Relay 1	Passive switch: NO/NC contact, up to 30 V / 1 A AC/DC
	Output 1	Active switch output: 8 up to 12 V DC depending on power supply (PoE: 10 V; adaptor: power supply voltage minus 2 V), max 400 mA
I/O Module* (Part No. 9155034)	ext.relay1	Passive relay switch: NO and NC contacts, up to 30 V / 2 A AC/DC
	ext.relay2	Passive relay switch: NO and NC contacts, up to 30 V / 2 A AC/DC

More modules marked by * can be used.

2.4 Extending Module Connection

2N® Helios IP Verso allows to connect following extending modules:

- [Infopanel](#)
- [Keypad](#)
- [RFID card reader 125 kHz](#)
- [RFID card reader 13.56 MHz](#)
- [I/O module](#)
- [5-button module](#)
- [Electronic buttons](#)
- [Wiegand module](#)
- [Tamper switch](#)
- [Blank module](#)
- [Security Relay](#)

Module Bus Interconnection

All the **2N® Helios IP Verso** modules, except for the Tamper Switch, are interconnected via a bus. The bus starts on the basic unit and goes over all the modules. The order of modules on the bus is irrelevant. And it also irrelevant which bus connector on the module is used as the input and which is used as the output.

The modules include a 220 mm long interconnecting cable; the Wiegand (9155037) and I/O modules (9155034) include an 80 mm long interconnecting cable.

You can order a separate 1 m long bus cable (9155050) for remote installation of the **2N® Helios IP Verso** modules. Typically, it helps install an RFID card reader on the opposite side of the wall on which the **2N® Helios IP Verso** intercom is installed.

The modules can be combined in each base as follows:

Module	Externally mounted (visible module)	Internally mounted (invisible module)	Internally mounted on bottom base edge
Infopanel	X		
Keypad	X		
RFID card reader 125 kHz	X		
RFID card reader 13.56 MHz	X		
I/O module		X	
5-button module	X		
Electronic buttons	X		
Wiegand module		X	
Tamper switch			X
Blank module	X		

Module Power Supply

Except for the protection switch module, all the **2N® Helios IP Verso** modules are powered from the bus. The available bus power output depends on the power supply type. Basic units 571v3 and higher can use a 3A power supply to increase the bus power available for the modules connected.

Power supply	Specification	Available power
External supply	12 V \pm 15% / 2 A (3 A)	24 W (36 W)
PoE	802.3af (Class 0 – 12.95 W)	12 W
Combined	External supply + PoE	30 W (42 W)

The count of modules on the bus is limited by the available power supply output. The maximum count of the modules on the bus is 30.

Basic unit (571v3)	Consumption [W] (Maximum value)
At relax	2.376
Infrared illumination	3.06
LED - call	0.072
LED - ringing	0.072
LED - lock	0.072
LED - secured	0.096
Button backlight	0.072
name tag backlight	0.072
Unit backlight	0.072
Relay 1	0.132
OUT 1	4.8
Audio	2.94
Total	13.84

Module	Idle consumption [W] (Minimum value)	Full load [W] (Maximum value)	Special elements [W]
Basic unit (571v3)	2.38	13.84	
Infopanel (version 2)	0.17	0.64	
Keypad (579v2)	0.20	1.55	
RFID card reader 125 kHz (584v2)			
RFID card reader 13.56 MHz (583v2)	0.42	0.89	
I/O module (577v2)	0.35	0.66	Closed relay 0.13
5-button module (578v2)	0.15	0.98	
Electronic buttons			
Wiegand module (581v1)			
Tamper switch	0	0	

Specimen configuration consumption computation

Module	Minimum consumption [W]	Maximum consumption [W]
Basic unit	2.38	13.84
RFID card reader 13.56 MHz (583v2)	0.42	0.89
I/O module (577v2)	0.35	0.66
Protective switch	0	0
5-button module (578v2)	0.15	0.98
I/O module (578v2)	0.15	0.98
Tamper switch	0	0
Wiegand module (581v1)	x	x
Total	3.45	17.34

It is obvious from the specimen configuration that all the modules have sufficient outputs when an external power supply is used. When a PoE supply is used, the power output is insufficient for all the modules, which results in automatic decrease in backlight level, active output current supply, volume and LED intensity. Some modules need a specific power output for their specific activities: the I/O module, e.g., requires 0.13 W for relay closing (not calculated for minimum consumption).

Infopanel Module

The Infopanel module (Part No. 9155030) is one of the **2N® Helios IP Verso** intercom elements and is used for inserting and backlighting printed information.

- The module contains two **2N® Helios IP Verso** bus connectors.
- These two connectors are fully interchangeable and can be used both as inputs from the basic unit and outputs to other modules.
- If this module is the last one on the bus, one of the connectors remains unconnected.
- The module package includes a 220 mm long interconnecting cable.

- Nametag dimensions: 69,2 (W) x 86,7 (H) mm (dimensional tolerance: +0; - 0,5 mm).
- Refer to www.2n.cz for printing template.

Keypad Module

The Keyboard module (Part No. 9155031) is one of the **2N® Helios IP Verso** intercom elements and provides a numerical input in the system.

- The module contains two **2N® Helios IP Verso** bus connectors.
- These two connectors are fully interchangeable and can be used both as inputs from the basic unit and outputs to other modules.
- If this module is the last one on the bus, one of the connectors remains unconnected.
- The module package includes a 220 mm long interconnecting cable.

RFID Card Reader Module 125 kHz

The 125 kHz RFID Card Reader (Part No. 9155032) is one of the **2N® Helios IP Verso** intercom elements and is used for reading RFID card Ids in the 125 kHz band.

- The module contains two **2N® Helios IP Verso** bus connectors.
- These two connectors are fully interchangeable and can be used both as inputs from the basic unit and outputs to other modules.
- If this module is the last one on the bus, one of the connectors remains unconnected.
- The module package includes a 220 mm long interconnecting cable.

The following RFID cards can be read:

- EM4100, EM4102, HID Proximity

RFID Card Reader 13.56 MHz

The 13.56 MHz RFID Card Reader (Part No. 9155033) is one of the **2N® Helios IP Verso** intercom elements and is used for reading RFID card Ids in the 13.56 MHz band.

- The module contains two **2N® Helios IP Verso** bus connectors.
- These two connectors are fully interchangeable and can be used both as inputs from the basic unit and outputs to other modules.
- If this module is the last one on the bus, one of the connectors remains unconnected.
- The module package includes a 220 mm long interconnecting cable.

The following RFID cards can be read:

- ISO14443A – Mifare Classic 1k & 4k, DESFire EV1, Mini, Plus S&X, SmartMX, Ultralight, Ultralight C, SLE44R35, my-d move (SLE66Rxx), PayPass, Legic Advant
- ISO14443B – Calypso, CEPAS, Moneo, SRI512, SRT512, SRI4K, SRIX4K, PicoPass, HID iCLASS

I/O Module

The I/O module (Part No. 9155034) is one of the **2N® Helios IP Verso** intercom elements and is used for extending the number of inputs and outputs.

- The module contains two **2N® Helios IP Verso** bus connectors.
- These two connectors are fully interchangeable and can be used both as inputs from the basic unit and outputs to other modules.
- If this module is the last one on the bus, one of the connectors remains unconnected.
- The module package includes an 80 mm long interconnecting cable.
- The inputs / outputs are addressed as follows: **<module_name>.<input/output_name>**, e.g. module5.relay1. The module name is configured in the Module name parameter in the Hardware / Extenders menu.

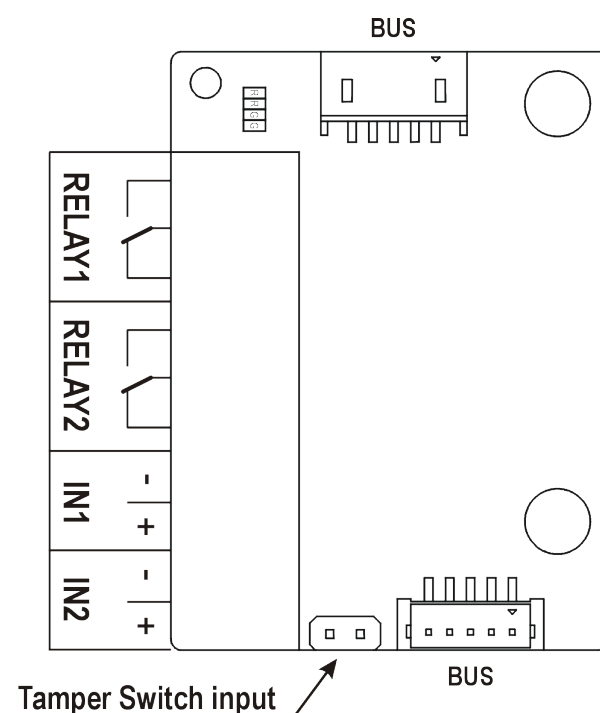

RELAY1	RELAY1 terminals with accessible 30 V / 1 A AC/DC NO/NC contact
RELAY2	RELAY2 terminals with accessible 30 V / 1 A AC/DC NO/NC contact
IN1	IN1 terminals for input in passive/ active mode (–30 V to +30 V DC) OFF = open OR $U_{IN} > 1.5 \text{ V}$ ON = closed contact OR $U_{IN} < 1.5 \text{ V}$
IN2	IN2 terminals for input in passive/active mode (–30 V to +30 V DC) OFF = open OR $U_{IN} > 1.5 \text{ V}$ ON = closed contact OR $U_{IN} < 1.5 \text{ V}$
TAMPER	Tamper switch (9155038) input

5-Button Module

The 5-button module (Part No. 9155035) is one of the **2N® Helios IP Verso** intercom elements and is used for extending the number of buttons.

- The module contains two **2N® Helios IP Verso** bus connectors.
- These two connectors are fully interchangeable and can be used both as inputs from the basic unit and outputs to other modules.
- If this module is the last one on the bus, one of the connectors remains unconnected.
- The module package includes a 220 mm long interconnecting cable.
- Nametag dimensions:
 - 1 button: 52,0 (W) x 15,2 (H) mm (dimensional tolerance: +0; - 0,5 mm).
 - 5 buttons: 57,5 (W) x 89,0 (H) mm (dimensional tolerance: +0; - 0,5 mm).
- Refer to www.2n.cz for nametag printing template.

Electronic Buttons

The Electronic buttons module (Part No. 9155036) is being prepared.

Wiegand Module

The Wiegand module (Part No. 9155037) is one of the **2N® Helios IP Verso** intercom elements and is used for connecting an external Wiegand device (RFID card reader, fingerprint or other biometric data reader) and/or connecting the **2N® Helios IP Verso** system to an external security exchange. All the inputs and outputs are galvanically isolated from the **2N® Helios IP Verso** system with insulation strength of 500 V DC.

- The module contains two **2N® Helios IP Verso** bus connectors.
- These two connectors are fully interchangeable and can be used both as inputs from the basic unit and outputs to other modules.
- If this module is the last one on the bus, one of the connectors remains unconnected.
- The module package includes an 80 mm long interconnecting cable.
- The module name is configured in the Module name parameter in the Hardware / Extenders menu.
 - The input LED IN is addressed as follows: **<module_name>.<input1>**, e.g. module2.input1.
 - The input Tamper is addressed as follows: **<module_name>.<tamper>**, e.g. module2.tamper.
 - The output LED OUT (negated) is addressed as follows: **<module_name>.<output1>**, e.g. module2.output1.

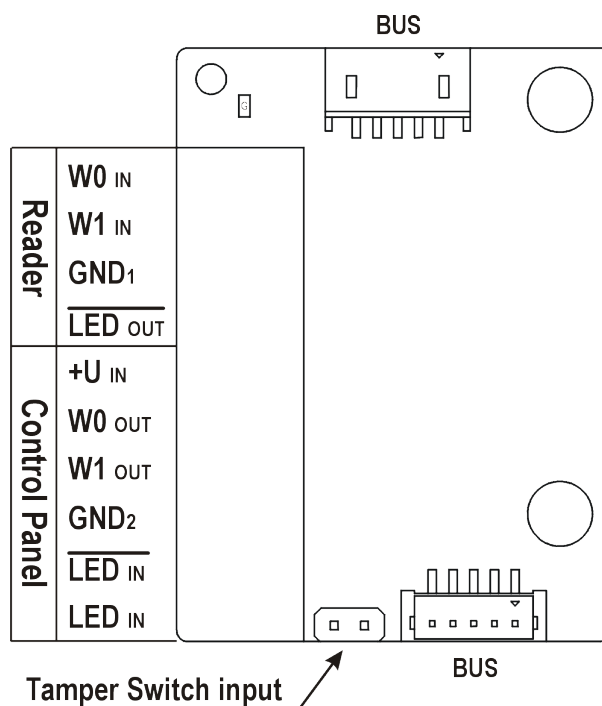

Reader	W0 IN, W1 IN , GND1	Isolated 2-wire WIEGAND IN
	LED OUT	Isolated open LED OUT switched against GND1 on WIEGAND IN side (up to 24 V / 50 mA)
Control Panel	+U IN	+U _{IN} (5 to 15 V DC) WIEGAND OUT power supply input
	W0 OUT, W1 OUT, GND2	Isolated 2-wire WIEGAND OUT
	LED IN (negated)	Isolated input for open LED IN, input activated by GND2
	LED IN	Isolated input for open LED IN, input activated by +U
	G	+U _{IN} WIEGAND OUT active supply LED indicator
	TAMPER	Tamper switch (Part No. 9155038) input

Tamper Switch Module

The Tamper Switch module (Part No. 9155038) is one of the **2N® Helios IP Verso** intercom elements and helps secure the system against tampering.

- The module contains two switches that open whenever the front frame is removed:
 - One switch leads directly to the terminal board and is designed for connection to an external security exchange (32 V DC / 50 mA max).
 - The other switch, together with the **I/O module (9155034)** or **Wiegand module (9155037)**, can be used for alarm signalling via the Automation interface in the **2N® Helios IP Verso** configuration.
 - This module is not connected to the bus.



Figure: Tamper Switch Mounting

Blank module

The Blank module (Part No. 9155039) is used to cover an empty position.

Security Relay

The **Security Relay** (Part No. 9159010) is used for enhancing security between the intercom and the connected electric lock. The **2N® Helios IP Security Relay** is designed for any **2N® Helios IP** intercom model with firmware versions 1.15 and higher. It significantly enhances security of the connected electric lock as it prevents lock opening by forced intercom tampering.



Function:

The **2N® Helios IP Security Relay** is a device installed between an intercom (outside the secured area) and the electric lock (inside the secured area). The **2N® Helios IP Security Relay** includes a relay that can only be activated if the valid opening code is received from the intercom.

Specifications:

- Passive switch: NO and NC contacts, up to 30 V / 1 A AC/DC
- Active switch output: 12 V / 700 mA DC
- Dimensions: (56 × 31 × 24) mm
- Weight: 20 g

Installation:

Install the **2N® Helios IP Security Relay** onto a two-wire cable between the intercom and the electric lock inside the area to be secured (typically behind the door). The device is powered and controlled via this two-wire cable and so can be added to an existing installation. Thanks to its compact dimensions, the device can be installed into a standard mounting box.

Connection:

Connect the **2N® Helios IP Security Relay** to the intercom as follows:

- To the intercom active output (OUT1 or OUT2) , or
- To the intercom relay output with a 12 V DC serial external power supply.

Connect the electric lock to the **2N® Helios IP Security Relay** output as follows:

- To the active 12 V / 700 mA DC output, or
- To the relay output with a serial external power supply.

The device also supports a Departure button connected between the 'PB' and 'HeliosIP' terminals. Press the Departure button to activate the output for 5 seconds.

Status signalling:

Green LED	Red LED	Status
blinking	off	Operational mode
on	off	Activated output
blinking	blinking	Programming mode – waiting for initialisation
on	blinking	Error – wrong code received

Configuration:

- Connect the **2N® Helios IP Security Relay** to the properly set intercom switch output; refer to the **2N® Helios IP Configuration Manual**. Make sure that one LED at least on the **2N® Helios IP Security Relay** is on or blinking.
- Press and hold the **2N® Helios IP Security Relay** Reset button for 5 seconds to put the device in the programming mode (both the red and green LEDs are blinking).
- Activate the intercom switch using the keypad, telephone, etc. The first code sent from the intercom will be stored in the memory and considered valid. After code initialisation, the **2N® Helios IP Security Relay** will pass into the operational mode (the green LED is blinking).

✔ **Tip**

- FAQ: [2N® Helios IP Security Relay – what it is and how to use it with 2N® Helios IP intercom?](#)

✔ **Tip**

- Video Tutorial: [Door intercoms 2N® Helios IP - Security Relay](#)

Connection:

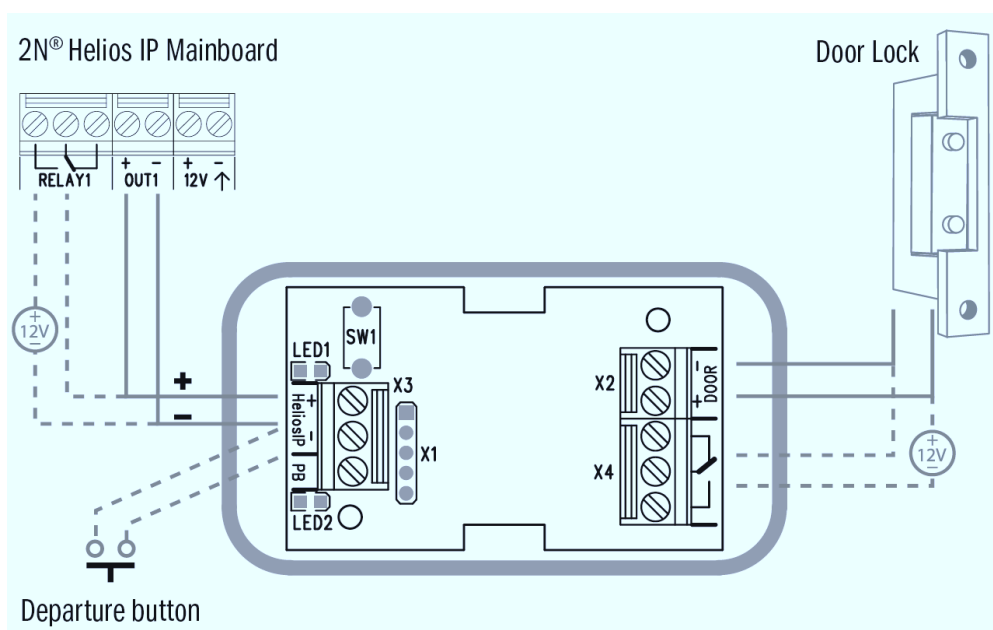

2.5 Completion

Installation Completion

Check the connection of all wires and the RJ-45 plug to the board connector.



Caution

- All unused connectors have to have tightened screws in order to avoid vibration caused by sound.

Nametag Placing

Every intercom package includes a piece of transparent foil, which can be laser printed. Cut the printed foil and insert the nametags in the buttons.

We recommend you to use separate foil for every button in the 5-button module. Refer to www.2n.cz for the nametag printing template.

Nametag dimensions for 5-button module:

- 1 button: 52.0 (W) x 15.2 (H) mm (dimensional tolerance: +0; - 0.5 mm)
- 5 buttons: 57.5 (W) x 89.0 (H) mm (dimensional tolerance: +0; - 0.5 mm)

Infopanel nametag dimensions: 69.2 (W) x 86.7 (H) mm (dimensional tolerance: +0; - 0.5 mm).



Caution

- The area where nametags are placed is called a wet zone. After heavy rain, water can penetrate to the nametag. Water in this area does not affect the intercom functionality in any way and evaporates soon.
- Always use waterproof foil (enclosed or other) for the nametags. Never use paper or ink jet printing to avoid damage due to water leakage!

Nametag inserting/replacing:

1. Remove the frame.
2. Lift up the button door. The 5-button module buttons have just one door.
3. Remove the used nametag and insert a new one.
4. Close the button door.
5. Replace the frame.

Frame Replacement

Check the frame sealing before replacing the frame.

Version A

- Screw the flush mounting frame in the upper and bottom parts.

Version B

- Hang the surface mounting frame on the hook in the upper part and then screw it tight in the bottom part.

Caution

- Improper mounting may deteriorate the intercom waterproofness and water may damage the electronic part.
- Make sure that all holes are filled with some waterproof material – the top part, around the cables and the screws.
- Use silicone or some other sealant to seal the box against the wall if uneven to avoid water leakage and wall damping..

Most Frequent Mounting Errors

At first, mount the metal bolts, level the bases on an even surface and tighten the screws.

Caution

- Make sure that the bases are levelled properly to avoid water leakage and electronic damage.

The examples in the figures below show incorrectly assembled bases. This happens, in particular, where the screws are tightened first.

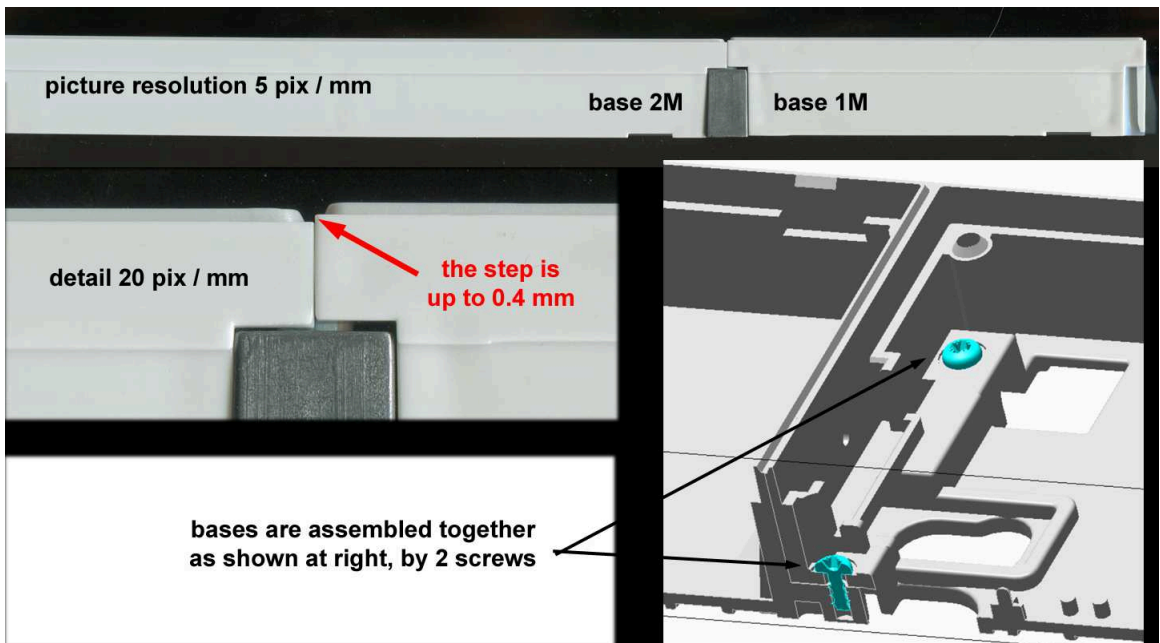
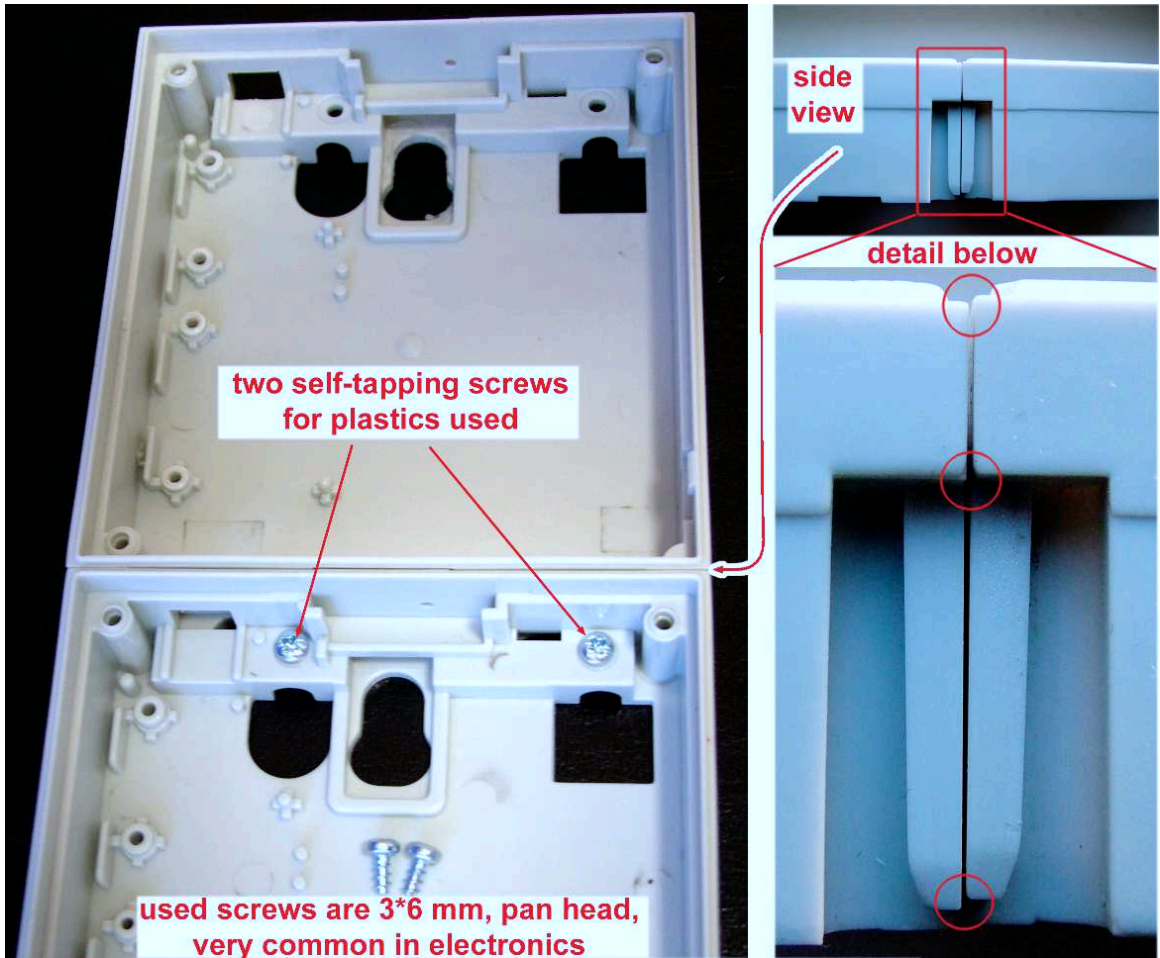

3. Function and Use

This section describes the basic and extending functions of the the **2N[®] Helios IP Verso** product.

Here is what you can find in this section:

- [3.1 Configuration](#)
- [3.2 Intercom Control as Viewed by External User](#)
- [3.3 Electronic Buttons equipped Intercom as Viewed by External User](#)
- [3.4 Intercom Control as Viewed by Internal User](#)
- [3.5 Maintenance](#)

3.1 Configuration

Configure **2N® Helios IP Verso** using your PC with any internet browser:

- Launch your internet browser (Internet Explorer, Firefox, etc.).
- Enter the IP address of your intercom (<http://192.168.1.100/>, e.g.).
- Log in using the username **Admin** and password **2n**.

You have to know your intercom IP address to log in to the integrated web server. Upon purchase, **2N® Helios IP Verso** is set to the dynamic IP address mode – it retrieves the IP address automatically if there is a properly configured DHCP server in the LAN. If no DHCP is available, operate **2N® Helios IP Verso** in the static IP address mode. Refer to the **2N® Helios IP Configuration Manual** for the **2N® Helios IP Verso** configuration details.

If your device remains inaccessible (you have forgotten the IP address, the network configuration has changed, etc.), you can change the network configuration using the device buttons.

IP Address Retrieval

Take the following steps to retrieve the **2N® Helios IP Verso** IP address:

- Connect (or, if connected, disconnect and reconnect) **2N® Helios IP Verso** to the power supply.
- Wait for the second sound signal .
- Press the quick dial button on the basic unit 5 times.
- **2N® Helios IP Verso** will read its IP address.
- If the address is 0.0.0.0, it means that the intercom has not obtained the IP address from the DHCP server.

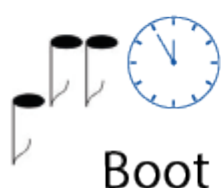



30 second

Note

- Be sure to press the button sequence within thirty seconds after the sound signal for security reasons. Up to 2 s intervals are allowed between the presses.

Dynamic/Static IP Address Switching

Take the following steps to switch the dynamic and static IP address mode in **2N[®] Helios IP Verso** :

- Connect (or, if connected, disconnect and reconnect) **2N[®] Helios IP Verso** to the power supply.
- Wait for the first sound signal  .
- Press the quick dial button on the basic unit 15 times.
- Switching is signalled with the sound signal  .
- Wait until the device is restarted automatically.
- Upon restart, the static IP address mode will be switched to the dynamic IP address mode and vice versa.



The following network parameters will be set after the static IP address mode is switched on and the device is restarted:

- IP address: 192.168.1.100
- Network mask: 255.255.255.0
- Default gateway: 192.168.1.1

Note

- Be sure to press the button sequence within thirty seconds after the sound signal for security reasons. Up to 2 s intervals are allowed between the presses.

3.2 Intercom Control as Viewed by External User

Quick Dial Buttons

Press the quick dial button on the basic unit to dial the first position in the phone directory (Phone Book) depending on the model type. Use extending modules to extend the number of quick dial buttons to up to 146.

By pressing the quick dial buttons you dial the phone numbers assigned to the particular Phone Book position. Call setup is signalled by a long intermittent or any other tone depending on the configuration of the PBX connected.



Repeated pressing of one and the same quick dial button during call setup may initiate call hangup or call termination plus dialling the next phone number of the called subscriber, or may be assigned no function; refer to the Intercom Configuration / Hardware / Keyboard subsection of Configuration Manual.

You can also press the  button anytime to hang up if enabled so in the **Hang up by #** parameter; refer to the Intercom Configuration / Hardware / Keyboard subsection of Configuration Manual.

Calling to Phone Book Position

The **2N® Helios IP Verso** Phone Book can contain up to 999 programmable positions. The quick dial buttons can only be used for positions 1 through 146, depending on the number of actually installed buttons. You can dial the other positions using the numeric keypad if the **Quick dialling with digits** function is enabled; refer to the Intercom Configuration / Hardware / Keyboard subsection of Configuration Manual.



Procedure:

- Enter the position number using the numeric keypad (05, 15, 200, e.g. – two digits at least and four digits at most) and press the  button for confirmation.
- You can also press the  button anytime to hang up if enabled so in the **Hang up by #** parameter; refer to the Intercom Configuration / Hardware / Keyboard subsection of Configuration Manual.

Calling to User-Defined Phone Number



If the **Telephone function enabled** (refer to the Intercom Configuration / Hardware / Keyboard subsection of Configuration Manual) parameter is selected, you can dial a user-defined phone number using the **2N® Helios IP Verso** numeric keypad.

Procedure:

1. Press .
2. You will hear a continuous tone from the speaker.
3. Enter the phone number via the numeric keypad and press  again to confirm your dialling.
4. You can also press the  button anytime to hang up if enabled so in the **Hang**

up by # parameter; refer to the Intercom Configuration / Hardware / Keyboard subsection of Configuration Manual.



Incoming Call Answering/Rejecting

If the automatic incoming call answering function is disabled (refer to the Intercom Configuration / Services / Phone / Calls subsection of Configuration Manual), the incoming call to **2N® Helios IP Verso** is signalled with loud ringing. Press  to answer the call and  to reject the call.

Door Opening (Switch Activation) by Code

2N® Helios IP Verso is equipped with a door unlocking switch. Enter the valid code (refer to the Intercom Configuration / Hardware / Switches subsection of Configuration Manual) using the numeric keypad to activate this switch.





Procedure:

- Enter the switch activating numerical code using the numeric keypad and press  for confirmation.
- A valid code is notified visually and by a continuous switch activation tone or a predefined unlocking user sound. An invalid code is signalled by the  sound or a user sound.

User Activation/Deactivation

Activate/deactivate a user using the numeric keypad in order to route calls directly to the phone numbers assigned to the user; refer to the Intercom Configuration / Directory / Phone Book Telephone Directory subsection of Configuration Manual for details.

Procedure:



- Enter the user activating/deactivating numerical code using the numeric keypad and press  for confirmation.
- A valid code is signalled by the  or  sound according to the code type. An invalid code is signalled by the  sound.

Profile Activation/Deactivation

Activate/deactivate a profile using the numeric keypad in order to route calls directly to the phone numbers tied with the profile; refer to the Intercom Configuration / Directory / Time Profiles subsection of Configuration Manual subsection for details.

Procedure:

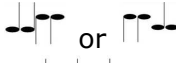
- Enter the profile activating/deactivating numerical code using the numeric keypad and press  for confirmation.

- A valid code is signalled by the  or  sound according to the code type.
An invalid code is signalled by the  sound.

3.3 Electronic Buttons equipped Intercom as Viewed by External User

The electronic button unit is unavailable yet.

3.4 Intercom Control as Viewed by Internal User

Call Answering

You can answer the incoming calls to the **2N® Helios IP Verso** intercom using your phone like any other calls. You can unlock the door, activate/deactivate a user/profile via your phone keypad during the call. The calls, however, are time-limited to avoid unintentional blocking of the **2N® Helios IP Verso** line. Set the maximum call duration in the **Call time limit** (refer to the Intercom Configuration / Services / Phone / Calls subsection of Configuration Manual). Press # on your phone anytime to extend the call time. The automatic call termination is signalled with a short beep 10 s before the call end.



Calling to 2N® Helios IP Verso

2N® Helios IP Verso allows you to answer incoming calls. Set the required parameters in the Incoming calls group; refer to the Intercom Configuration / Services / Phone / Calls subsection of Configuration Manual.

Door Opening (Switch Activation) by Code

2N® Helios IP Verso is equipped with a door unlocking switch. Enter the valid code (refer to the Intercom Configuration / Hardware / Switches subsection of Configuration Manual) using your phone keypad to activate this switch.





Procedure:

- Enter the switch 1 or 2 activating code using your phone keypad and press  for confirmation. Confirmation is unnecessary if the **Lock code without confirmation** is enabled, refer to the Intercom Configuration / Hardware / Switches / Advanced subsection of Configuration Manual.
- A valid code is signalled by the  sound. An invalid code is signalled by the  sound.

User Activation/Deactivation

Activate/deactivate a user using your phone in order to route calls directly to the phone numbers assigned to the user, refer to the Intercom Configuration / Directory / Phone Book subsection of Configuration Manual for details.





Procedure:

- Enter the user activating/deactivating code using your phone keypad and press  for confirmation.
- A valid code is signalled by the  or  according to the code type. An invalid code is signalled by the  sound.

Profile Activation/Deactivation

Activate/deactivate a profile using your phone in order to route calls directly to the phone numbers tied with the profile, refer to the Intercom Configuration / Directory / Time Profiles subsection of Configuration Manual for details.

Procedure:

- Enter the profile activating/deactivating code using your phone keypad and press  for confirmation.
- A valid code is signalled by the  or  sound according to the code type. An invalid code is signalled by the  sound.

3.5 Maintenance

If used frequently, the device surface, the keypad in particular, gets dirty. Use a piece of soft cloth moistened with clean water to clean the device.

 **Warning**

- Do not use aggressive detergents (such as abrasives or strong disinfectants).

 **Warning**

- Prevent water from getting inside the intercom.

 **Tip**

- Clean the device in dry weather so that waste water can evaporate quickly.

4. Technical Parameters

Signalling protocol

- **SIP (UDP, TCP, TLS)**

Buttons

- **Button design:** White-backlit transparent buttons with replaceable nametags
- **Button count:** 1 and increments of 5
- **Button extenders:** Up to 30 modules, limited by power supply
- **Numeric keypad:** Optional

Audio

- **Microphone:** 1 integrated microphone
- **Amplifier:** 2 W (class D) amplifier
- **Speaker:** 2 W / 8 Ω
- **Output LINE OUT:** 1 VRMS / 600 Ω
- **Volume control:** Adjustable with automatic adaptive mode
- **Full duplex:** Yes (AEC)

Audio stream

- **Protocols:** RTP / RTSP
- **Codecs:** G.711, G.729, G.722, L16/16kHz

Camera

- **Sensor:** 1/3" colour CMOS
- **JPEG resolution:** Up to 1280 (H) × 960 (V)
- **Video resolution:** 640 (H) × 480 (V)
- **Frame rate:** Up to 30 snapshots/s
- **Sensitivity:** 5.6 V/lux-sec (550 nm)
- **View angle:** 128° (H), 95° (V), 155° (D)
- **Infrared light:** Yes
- **Focal length:** 2.25 mm

Video stream

- **Protocols:** RTP / RTSP / HTTP
- **Codecs:** H.263, H.263+, H.264, MPEG-4, M-JPEG
- **IP camera function:** Yes, ONVIF v2.2 profile S compatible

Interface

- **Power supply:** 12 V ±15 % / 2 A DC or PoE
- **PoE:** PoE 802.3af (Class 0 – 12.95 W)
- **LAN:** 10/100BASE-TX with Auto-MDIX, RJ-45
- **Recommended cabling:** Cat-5e or higher
- **Supported protocols:** SIP2.0, DHCP opt. 66, SMTP, 802.1x, RTSP, RTP, TFTP, HTTP, HTTPS, Syslog
- **Passive switch:** NO/NC contact, up to 30 V / 1 A AC/DC
- **Active switch output:** 8 up to 12 V DC depending on power supply (PoE: 10 V; adaptor: power supply voltage minus 2 V), max 400 mA

RFID card reader

- **Optionally 125 kHz or 13.56 MHz**
- **Supported cards, 125 kHz, Part No. 9155032:**
 - EM4100, EM4102, HID Prox
- **Supported cards, 13.56 MHz, Part No. 9155033** (only card serial number is read)
 - ISO14443A
 - Mifare Classic 1k & 4k, DESFire EV1, Mini, Plus S&X, SmartMX, Ultralight,
 - Ultralight C, SLE44R35, my-d move (SLE66Rxx), PayPass, Legic Advant
 - ISO14443B
 - Calypso, CEPAS, Moneo, SRI512, SRT512, SRI4K, SRIX4K, PicoPass, HID iCLASS
- **Supported cards on 13.56 MHz NFC version, Part No. 9155040** (only card serial number is read)
 - ISO14443A
 - Mifare Classic 1k & 4k, DESFire EV1, Mini, Plus S&X, SmartMX, Ultralight,
 - Ultralight C, SLE44R35, my-d move (SLE66Rxx), PayPass, Legic Advant
 - ISO14443B
 - Calypso, CEPAS, Moneo, SRI512, SRT512, SRI4K, SRIX4K, PicoPass, HID iCLASS
 - NFC
 - SmartPhone with NFC/HCE support, since Android version 4.3

Mechanical properties

- **Cover:** Robust zinc casting with surface finish
- **Working temperature:** -40°C – 60°C
- **Working relative humidity:** 10% – 95% (non-condensing)
- **Storing temperature:** -40°C – 70°C
- **Dimensions**
 - Surface mounting frame:
 - 1 modul: 107 (W) x 130 (H) x 28 (D) mm
 - 2 moduls: 107 (W) x 234 (H) x 28 (D) mm
 - 3 moduls: 107 (W) x 339 (H) x 28 (D) mm
 - Flush mounting frame:
 - 1 modul: 130 (W) x 153 (H) x 5 (D) mm
 - 2 moduls: 130 (W) x 257 (H) x 5 (D) mm
 - 3 moduls: 130 (W) x 361 (H) x 5 (D) mm
 - Flush mounting box (minimum hole dimensions):
 - 1 modul: 108 (W) x 131 (H) x 45 (D) mm
 - 2 moduls: 108 (W) x 238 (H) x 45 (D) mm
 - 3 moduls: 108 (W) x 343 (H) x 45 (D) mm
- **Weight** – Max net weight: 2 kg / max gross weight: 2.5 kg - based on configuration
- **Covering level** – IP54

5. Supplementary Information

Here is what you can find in this section:

- [5.1 Troubleshooting](#)
- [5.2 Directives, Laws and Regulations](#)
- [5.3 General Instructions and Cautions](#)

5.1 Troubleshooting



For the most frequently asked questions refer to faq.2n.cz.

5.2 Directives, Laws and Regulations

Europe

2N® Helios IP Verso conforms to the following directives and regulations:

Directive 1999/5/EC of the European Parliament and of the Council, of 9 March 1999 – on radio equipment and telecommunications terminal equipment and the mutual recognition of their conformity

Directive 2006/95/EC of the European Parliament and of the Council of 12 December 2006 on the harmonisation of the laws of Member States relating to electrical equipment designed for use within certain voltage limits

Directive 2004/108/EC of the Council of 15 December 2004 on the harmonisation of the laws of Member States relating to electromagnetic compatibility

Commission Regulation (EC) No. 1275/2008, of 17 December 2008, implementing Directive 2005/32/EC of the European Parliament and of the Council with regard to ecodesign requirements for standby and off mode electric power consumption of electrical and electronic household and office equipment

Directive 2011/65/EU of the European Parliament and of the Council of 8 June 2011 on the restriction of the use of certain hazardous substances in electrical and electronic equipment

Regulation (EC) No. 1907/2006 of the European Parliament and of the Council of 18 December 2006 concerning the Registration, Evaluation, Authorisation and Restriction of Chemicals (REACH), establishing a European Chemicals Agency, amending Directive 1999/45/EC and repealing Council Regulation (EEC) No. 793/93 and Commission Regulation (EC) No. 1488/94 as well as Council Directive 76/769/EEC and Commission Directives 91/155/EEC, 93/67/EEC, 93/105/EC and 2000/21/EC

Directive 2012/19/EC of the European Parliament and of the Council of 4 July 2012 on waste electrical and electronic equipment.

Industry Canada

This Class B digital apparatus complies with Canadian ICES-003. / Cet appareil numérique de la classe B est conforme a la norme NMB-003 du Canada.

FCC

NOTE: This equipment has been tested and found to comply with the limits for a Class B digital device, pursuant to part 15 of the FCC Rules. These limits are designed to provide reasonable protection against harmful interference in a residential installation. This equipment generates, uses and can radiate radio frequency energy and, if not installed and used in accordance with the instructions, may cause harmful interference to radio communications. However, there is no guarantee that interference will not occur in a particular installation. If this equipment does cause harmful interference to radio or television reception, which can be determined by turning the equipment off and on, the user is encouraged to try to correct the interference by one or more of the following measures:

- Reorient or relocate the receiving antenna
- Increase the separation between the equipment and receiver
- Connect the equipment into an outlet on a circuit different from that to which the receiver is connected
- Consult the dealer or an experienced radio/TV technician for help.

Changes or modifications to this unit not expressly approved by the party responsible for compliance could void the user's authority to operate this equipment.

5.3 General Instructions and Cautions

Please read this User Manual carefully before using the product. Follow all instructions and recommendations included herein.

Any use of the product that is in contradiction with the instructions provided herein may result in malfunction, damage or destruction of the product.

The manufacturer shall not be liable and responsible for any damage incurred as a result of a use of the product other than that included herein, namely undue application and disobedience of the recommendations and warnings in contradiction herewith.

Any use or connection of the product other than those included herein shall be considered undue and the manufacturer shall not be liable for any consequences arisen as a result of such misconduct.

Moreover, the manufacturer shall not be liable for any damage or destruction of the product incurred as a result of misplacement, incompetent installation and/or undue operation and use of the product in contradiction herewith.

The manufacturer assumes no responsibility for any malfunction, damage or destruction of the product caused by incompetent replacement of parts or due to the use of reproduction parts or components.

The manufacturer shall not be liable and responsible for any loss or damage incurred as a result of a natural disaster or any other unfavourable natural condition.

The manufacturer shall not be held liable for any damage of the product arising during the shipping thereof.

The manufacturer shall not make any warrant with regard to data loss or damage.

The manufacturer shall not be liable and responsible for any direct or indirect damage incurred as a result of a use of the product in contradiction herewith or a failure of the product due to a use in contradiction herewith.

All applicable legal regulations concerning the product installation and use as well as provisions of technical standards on electric installations have to be obeyed. The manufacturer shall not be liable and responsible for damage or destruction of the product or damage incurred by the consumer in case the product is used and handled contrary to the said regulations and provisions.

The consumer shall, at its own expense, obtain software protection of the product. The manufacturer shall not be held liable and responsible for any damage incurred as a result of the use of deficient or substandard security software.

The consumer shall, without delay, change the access password for the product after installation. The manufacturer shall not be held liable or responsible for any damage incurred by the consumer in connection with the use of the original password.

The manufacturer also assumes no responsibility for additional costs incurred by the consumer as a result of making calls using a line with an increased tariff.

Electric Waste and Used Battery Pack Handling



Do not place used electric devices and battery packs into municipal waste containers. An undue disposal thereof might impair the environment!

Deliver your expired electric appliances and battery packs removed from them to dedicated dumpsites or containers or give them back to the dealer or manufacturer for environmental-friendly disposal. The dealer or manufacturer shall take the product back free of charge and without requiring another purchase. Make sure that the devices to be disposed of are complete.

Do not throw battery packs into fire. Battery packs may not be taken into parts or short-circuited either.

**2N TELEKOMUNIKACE a.s.**

Modřanská 621, 143 01 Prague 4, Czech Republic

Phone: +420 261 301 500, Fax: +420 261 301 599

E-mail: sales@2n.cz

Web: www.2n.cz

EN2060_v2.0.1